

ROLL MATE INSTALLATION INSTRUCTIONS

MITSUBISHI TRITON MV MY2024+ DUAL CAB

This instructions has QR codes on relevant sections. You must scan the QR codes via your smart phone camera and watch the video to ensure your fitment is to standard.

Note: Images and footage used are examples only and may not resemble your vehicle.



INSTALLATION TIME: 45min (Approximately)

<p>IMPORTANT</p>	<ul style="list-style-type: none"> • Do not stand/sit or rest heavy objects on Roll Mate. • Do not drive with animals or people inside tub. • Tonneau Cover is not dust or water proof. • If contact with volatile chemicals occur, clean Cover with mild detergent and water solution.
<p>Care Instructions</p>	<ul style="list-style-type: none"> • Read Instructions fully before commencing installation. • Clean Cover with a mild detergent and water solution • Do not use abrasive cleaners or solvents • Refer to manufactures instructions applicable to power drill. • Protect Tub floor against scratches during installation process.
<p>Maintenance</p>	<ul style="list-style-type: none"> • Clean the cover regularly using a mild detergent and water solution. • Regularly inspect all hardware (bolts & nuts) to ensure they remain tightened to the recommended torque settings.
<p>Tools Required</p>	<ul style="list-style-type: none"> • Pen / Marker • Caulking Gun • Silicon - Non Acetic • Scissors & Knife • Trim Removal Tool • Spanner & Socket • Tape measure • Soapy water solution • Allen Key set • Screw driver

PERSONAL PROTECTIVE EQUIPMENT:



Rubber glove



Goggles



Hearing Protection

BOX CONTENTS

PART NO: **20080381501**
LEFT SIDE RAIL

QTY: 1

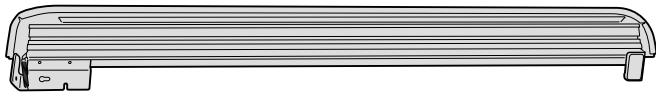





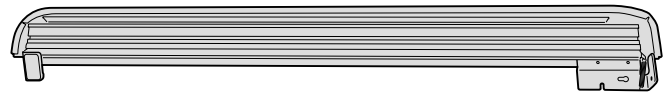



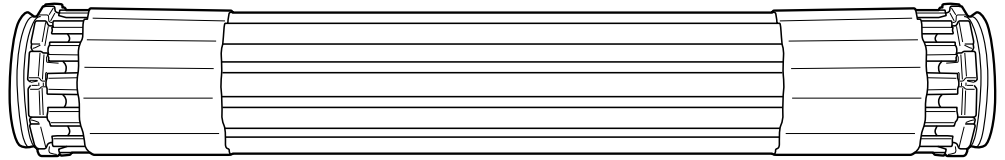



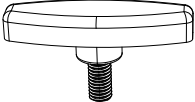
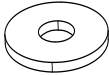

PART NO: **20081732401**
RIGHT SIDE RAIL

QTY: 1

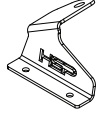
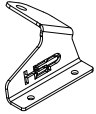
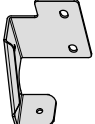
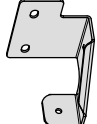

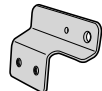
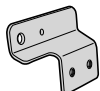
PART NO: **20080489901**
TOP COVER



<p>3006627</p>  <p>Allen Key S5 QTY: 1</p>	<p>20051257601</p>  <p>M6 T-Nut QTY: 6</p>	<p>20081320501</p>  <p>M6 Socket Head Bolt Assembly QTY: 14</p>	<p>20056470001</p>  <p>Strap & Buckle QTY: 2</p>	<p>20054717601</p>  <p>Connecting Key QTY: 2</p>	<p>20054793501</p>  <p>Long T-Nut QTY: 2</p>
<p>20054717501</p>  <p>T-Knob QTY: 2</p>	<p>HSP 3000247</p>  <p>M8 x 3mm Thick Flat Washer QTY: 2</p>	<p>HSP 3000147</p>  <p>M8 SPRING WASHER Qty - 2</p>	<p>20022739101</p>  <p>Self Drilling Screw QTY: 4</p>	<p>HSP 20085436101</p>  <p>LH - Hook Bracket QTY: 1</p>	<p>HSP 20085436201</p>  <p>RH - Hook Bracket QTY: 1</p>
<p>20080545201</p>  <p>FL Bracket QTY: 1</p>	<p>20080538701</p>  <p>FR Bracket QTY: 1</p>	<p>20080488001</p>  <p>RR Bracket QTY: 1</p>	<p>20080532101</p>  <p>RL Bracket QTY: 1</p>	<p>20082289901</p>  <p>RR Tub Bracket QTY: 1</p>	<p>20082289701</p>  <p>RL Tub Bracket QTY: 1</p>
<p>HSP 20082403201</p>  <p>Protective Tape QTY: 2</p>	<p>HSP 20081362301</p>  <p>D-shaped Rubber QTY: 1</p>	<p>20035177401</p>  <p>Adhesion Promoter QTY: 5</p>			

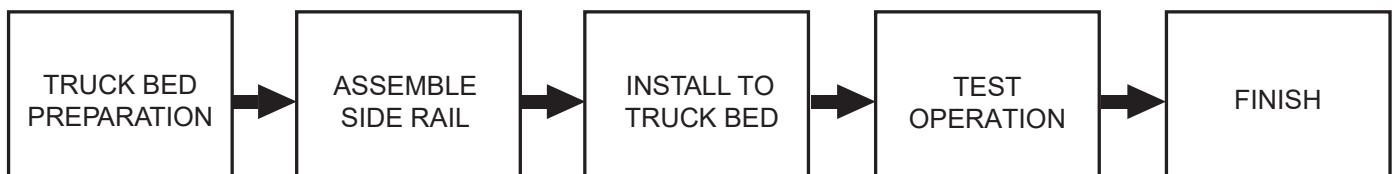

Carefully unpack the contents of the box.

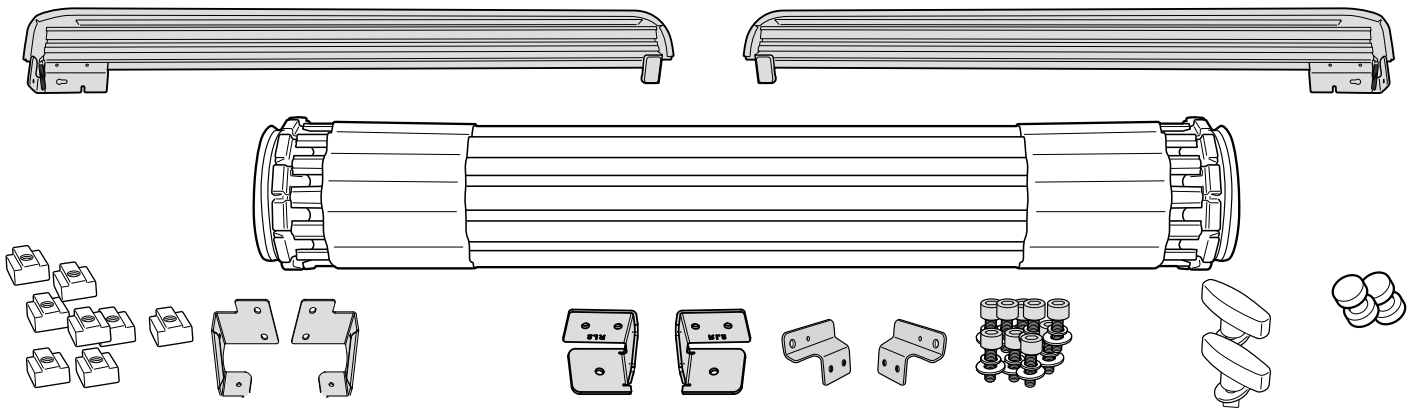

NOTE: Instructions may refer to one side of vehicle, repeat steps to the other side.

TUB PREPARATION

- 1 If the Vehicle is fitted with a cabin guard, sports styling bar or sail plane, remove from Ute Tub (truck bed) and retain.

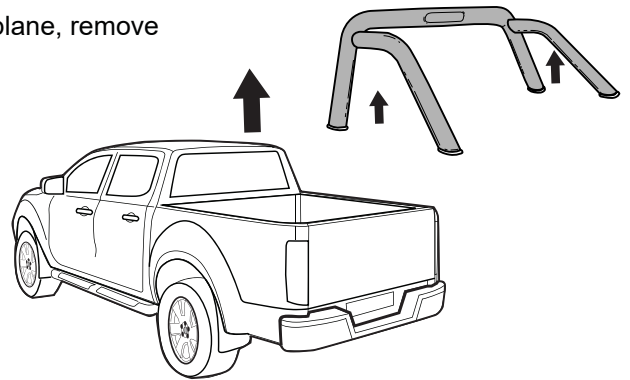

- 2 a. Unfasten and retain the indicated factory bolt.
b. Unfasten and retain the indicated factory bolt and tie down points.

Vehicles fitted with a tub liner:

1. Measure 50mm toward the rear of the tub from the indicated corner trim line of the tub liner, and 45mm down from the top edge of the liner. Mark the lines as indicated.
2. Trim along the marked lines and remove the cut section to expose the factory M8 Torx head bolt.

Note: This step is necessary for later stages of the installation.

Vehicles fitted with a tub liner.

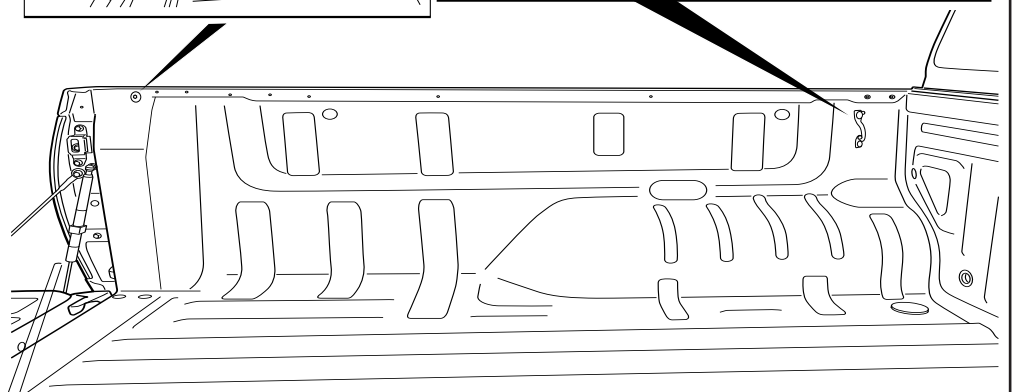
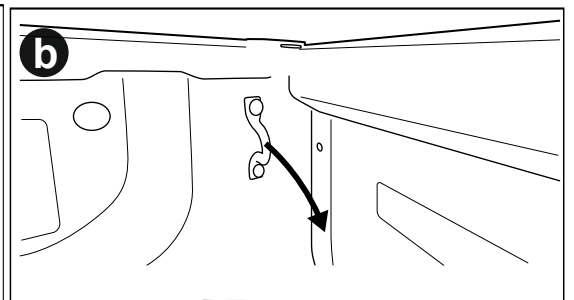
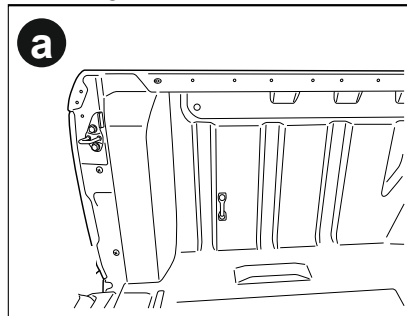
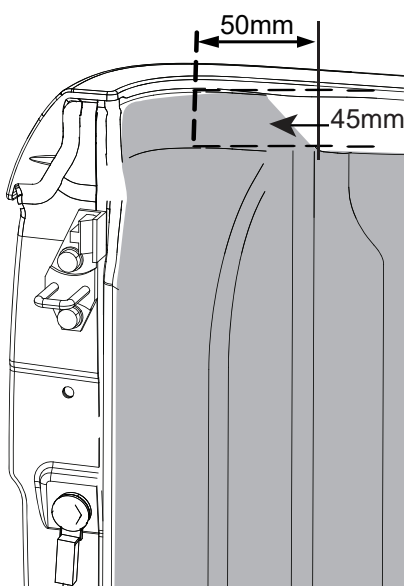

3

- a. Clean the area as indicated.
- b. Using only one adhesion promoter, apply it to the top surface of the headboard. Allow it to tack off for 1-2 minutes before proceeding to the next step.
- c. Place the D-shaped rubber seal flush against the rear edge of the headboard (the edge facing the tailgate). Ensure it fits snugly against the headboard panel joins. Peel back the backing paper from the seal and apply firm pressure along the entire seal to ensure proper adhesion. **Note:** You may need to trim excess where required.
- d. Apply sealant to the headboard panel join line and any exposed gaps or holes on the front panel of the Ute bed.
- e. Apply sealant to the opening of the D-mould and over the tub's top rail as indicated.

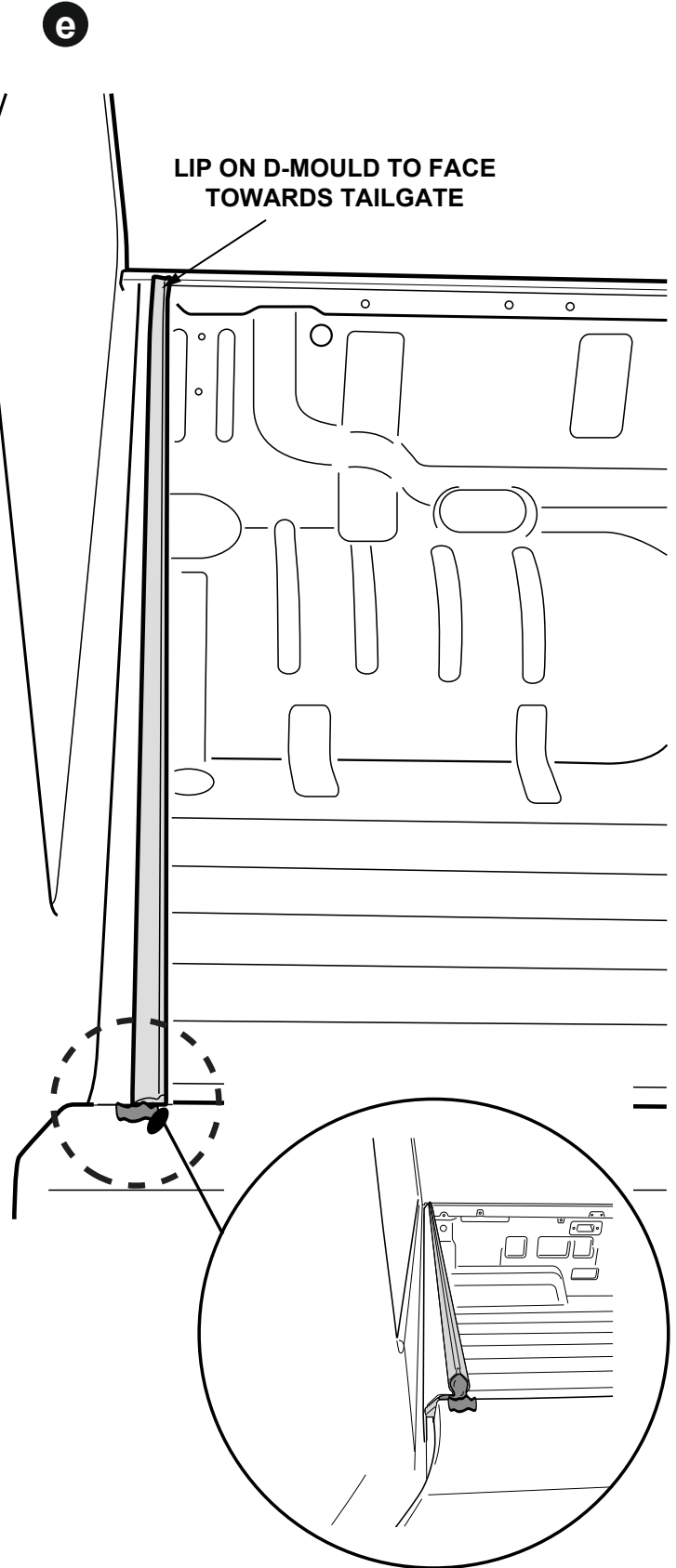
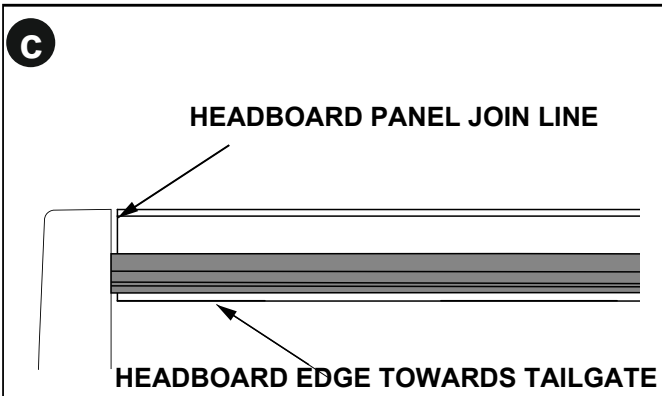
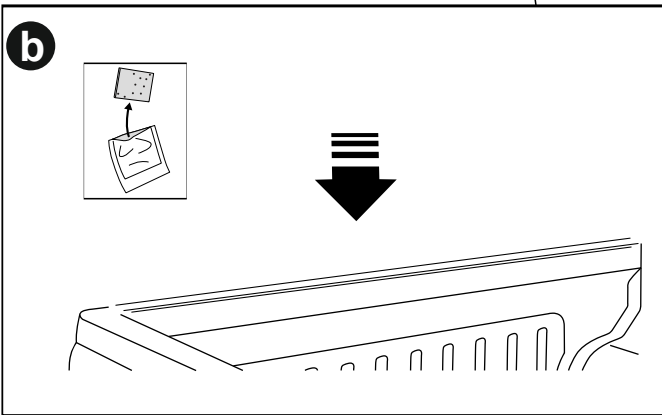
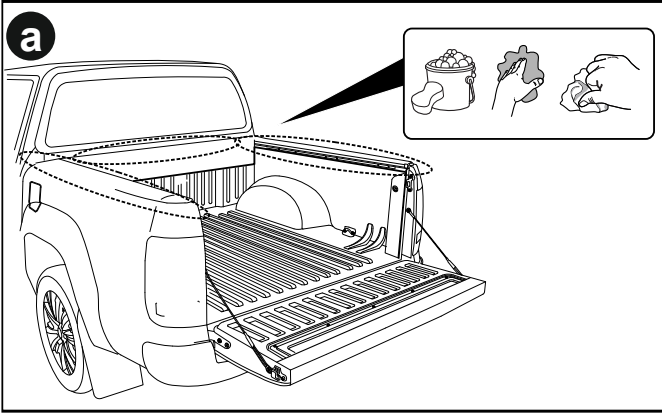

ROLL MATE ASSEMBLY

NOTE: If you are re-fitting the factory sailplane, please refer to the instructions located inside the 2010-PL1-RM kit box before proceeding with the following steps.

With care, lay the side rails down on a protective mat to avoid any damage.

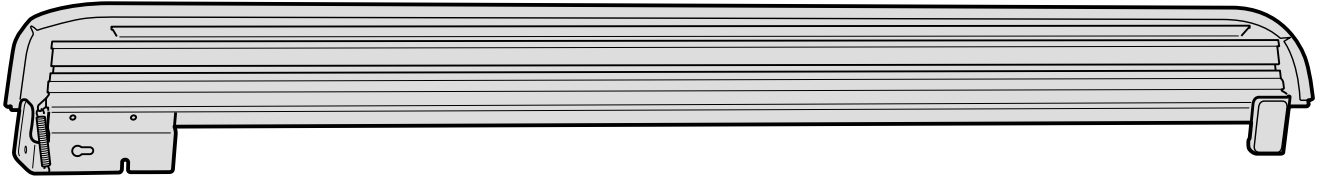

In the specified orientation, feed three M6 T-Nuts into the indicated channel of the side rail.

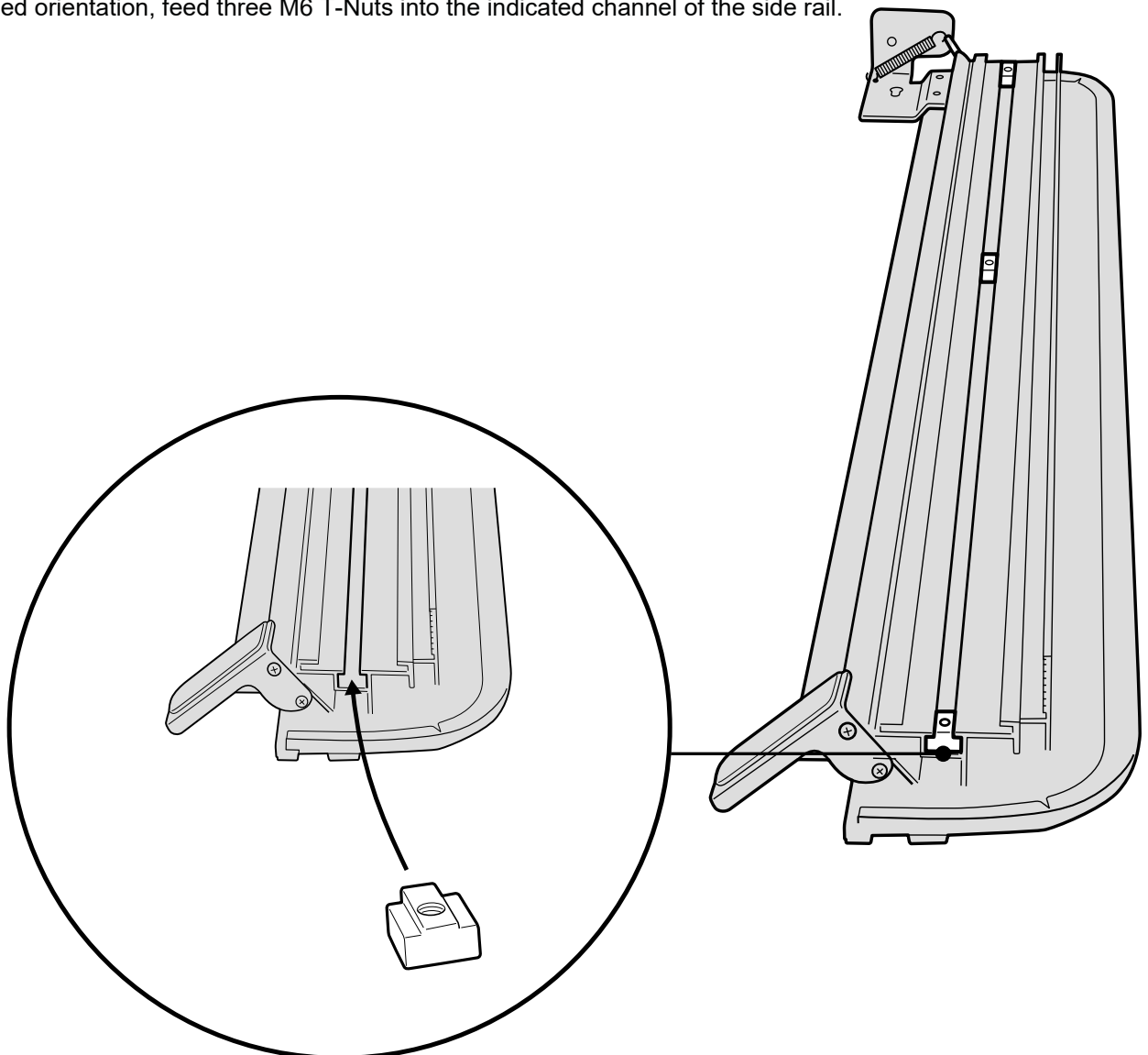

3

Left-hand side rail shown:

The indicated brackets will be installed in the order and orientation shown below.

Note: The indicated M6 T-Nut must remain in its specified location and will not be used until later steps in these instructions.

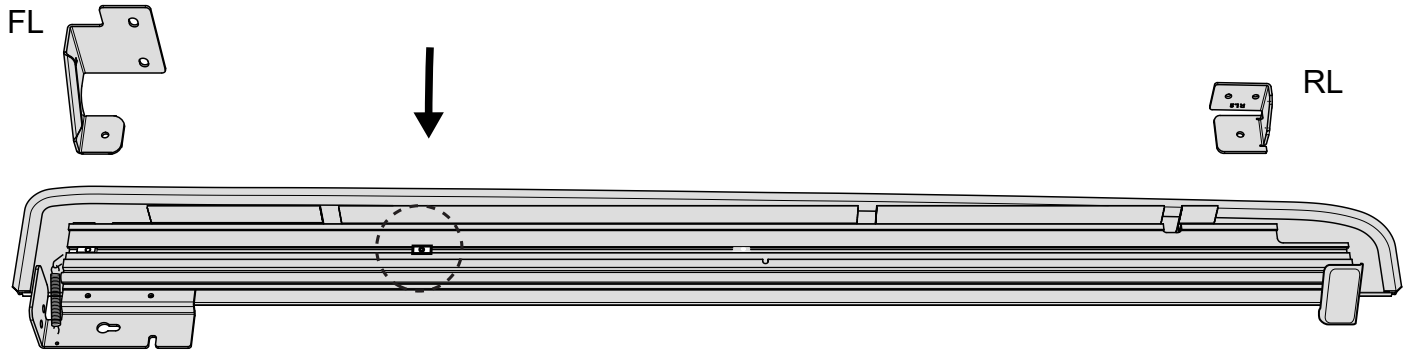

4

In the specified orientation, feed the FL and RL Brackets into the indicated channel of the side rail. Push them in until they either bottom out or stay positioned near the ends.

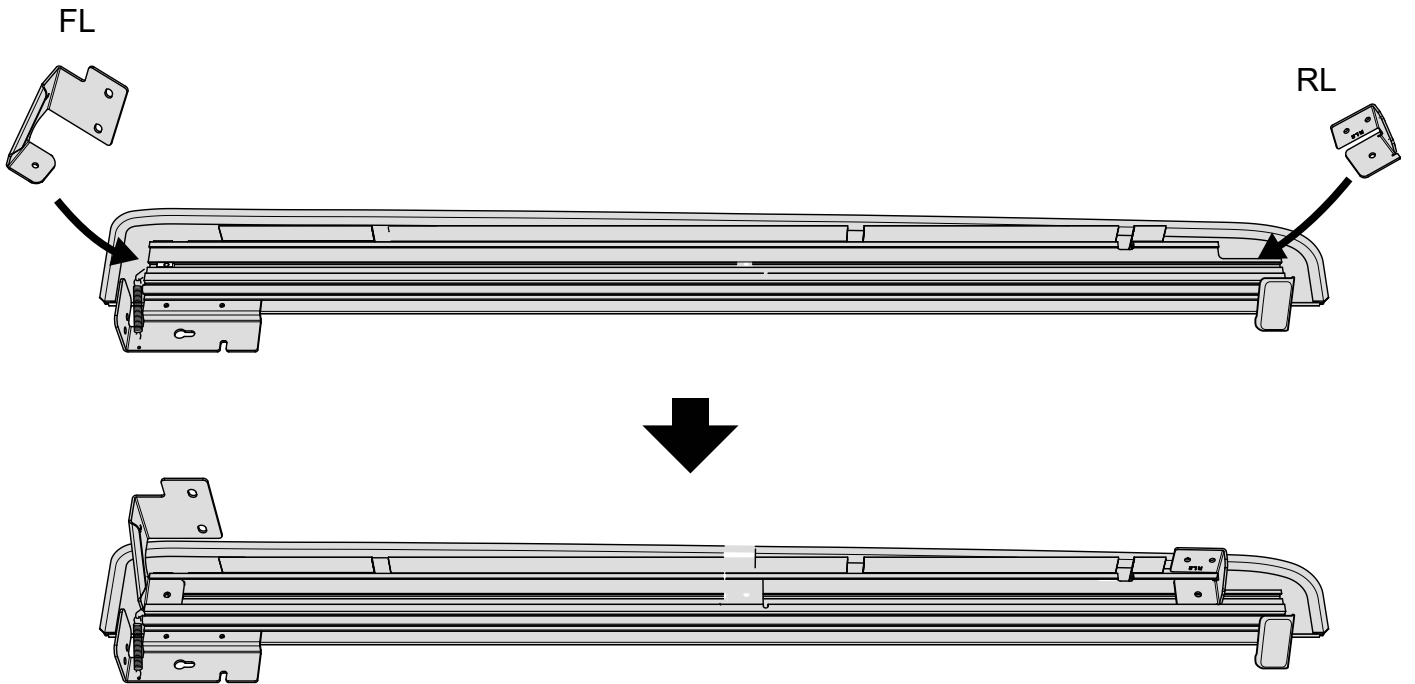

5

Loosely secure in place using the supplied socket head bolt, with the spring and flat washers already loaded.

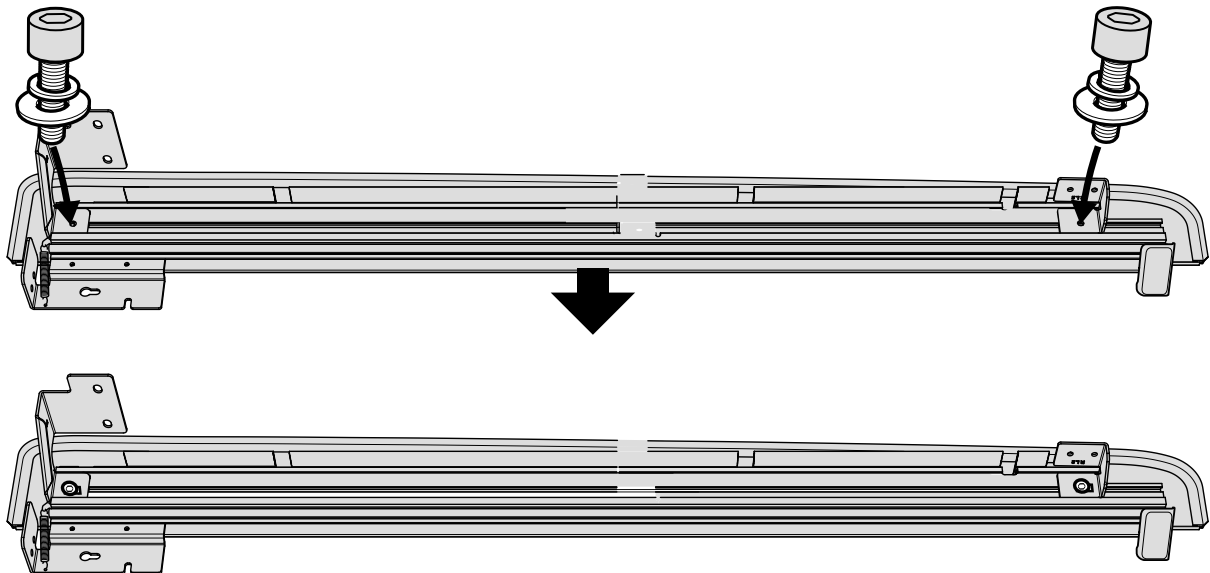

6 **For vehicles fitted with a tub liner:**

1. Carefully position the side rail on top of the tub's top rail.
2. Push the side rail forward until the front side rail brackets make firm contact with the headboard.
In the indicated areas of the front bracket, align the bracket holes with the threaded holes in the tub, ensuring proper alignment for the next steps.
3. Mark around the outer edge of each bracket, maintaining a 10mm gap from the bracket.
Then remove the side rail from the tub.
4. Trim along the marked lines and discard the removed sections.
Repeat all steps on the opposite side.

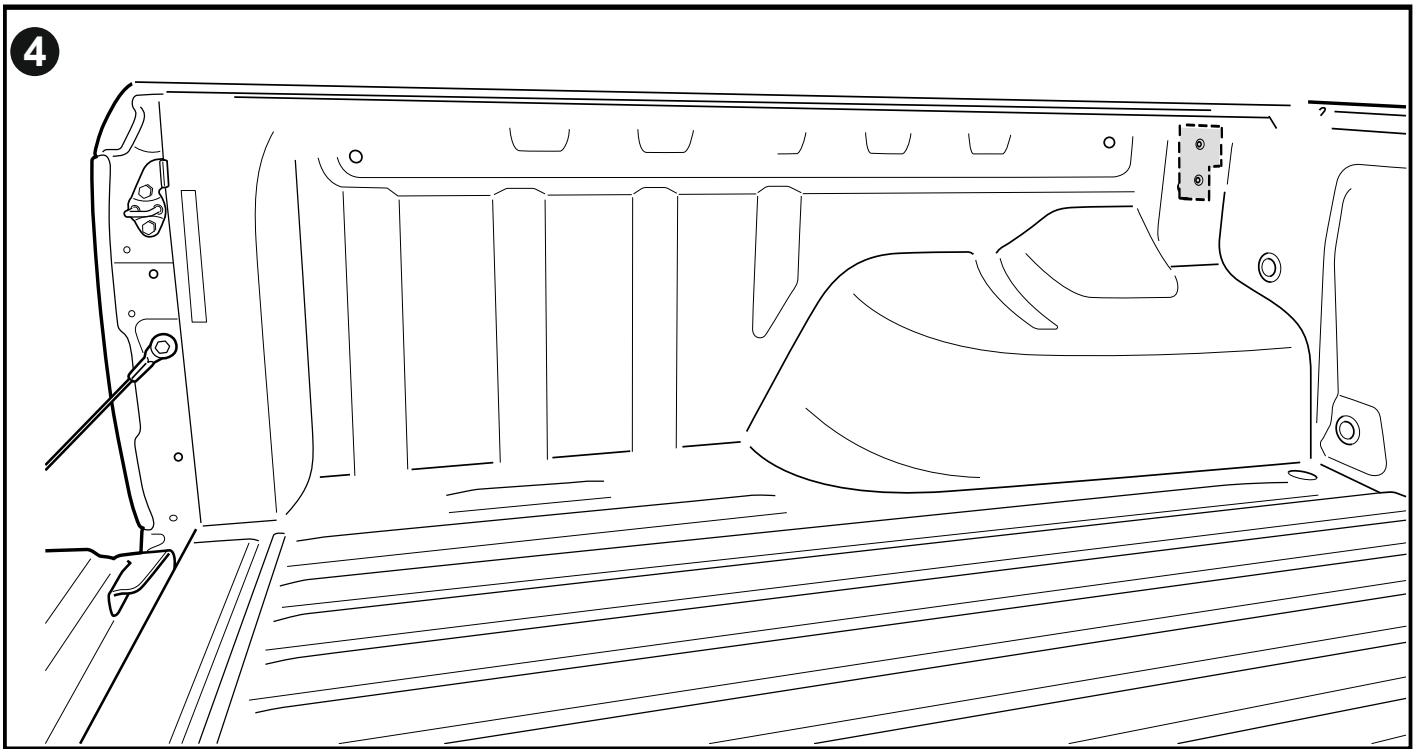
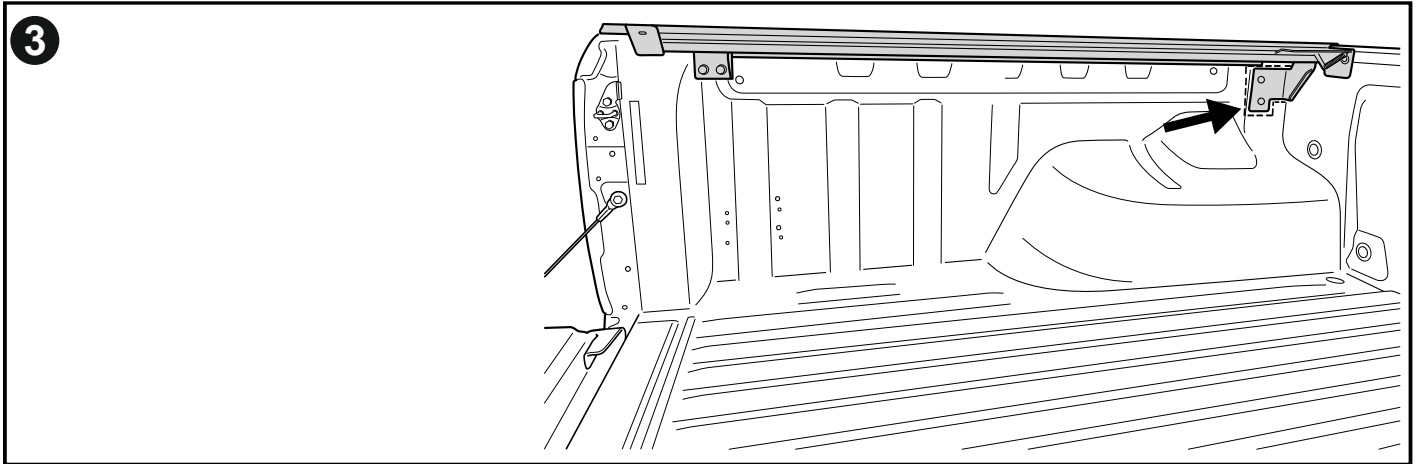
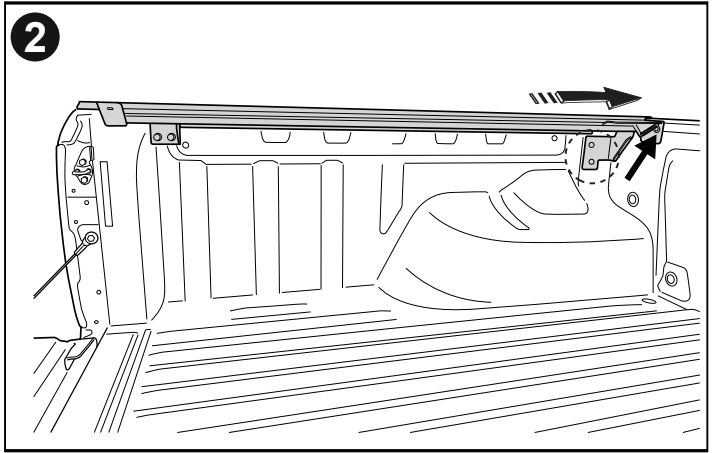
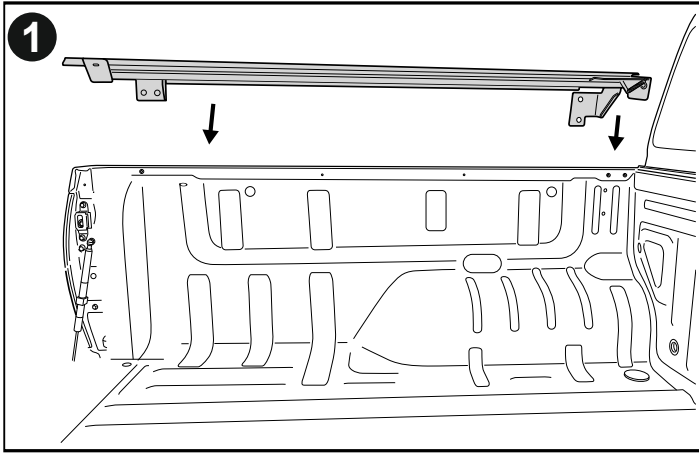

7

- a. Using the retained factory bolt, loosely fasten the RL tub bracket into place by feeding the bolt through the RL tub brackets hole and into the factory thread at the indicated location. Ensure the bracket is leveled and aligned with the top of the tub's rail by moving it up or down as needed. Once properly aligned, securely tighten the factory bolt.
- b. Now, fasten into position using the provided self drilling screw.

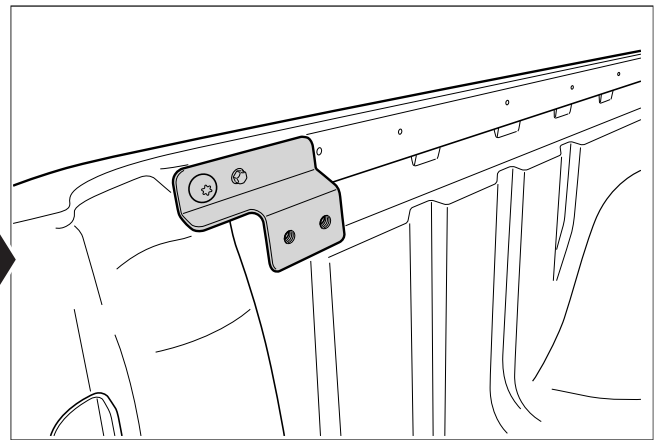
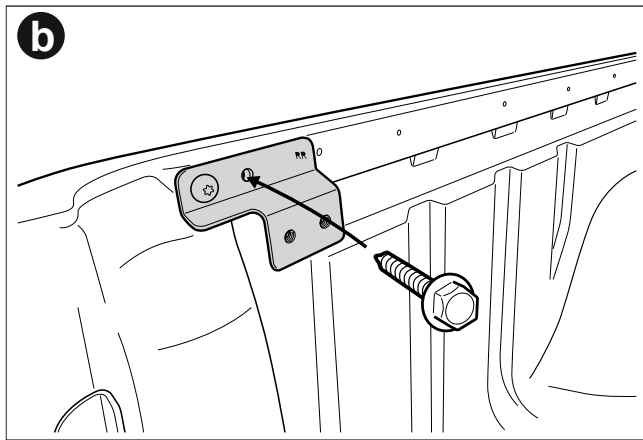
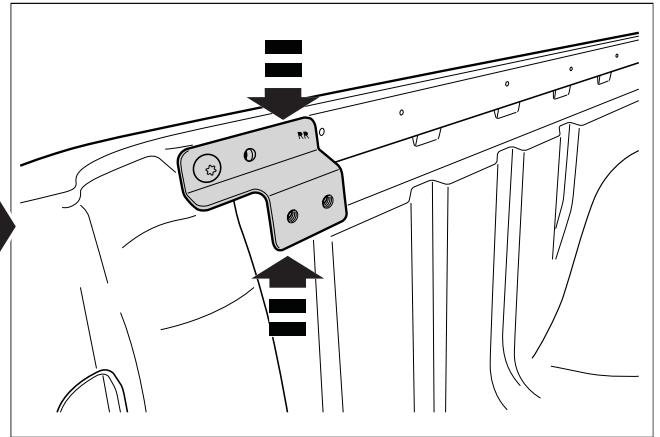
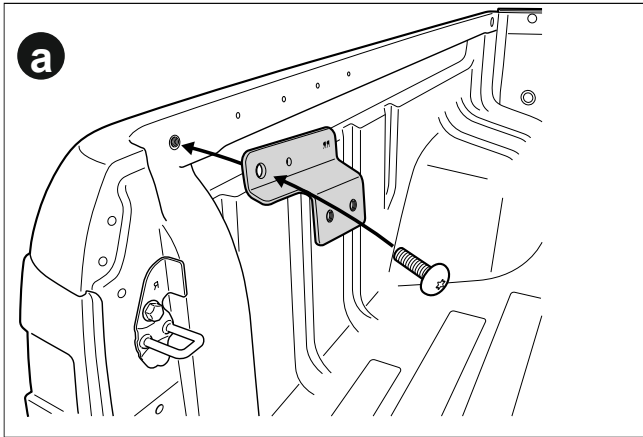

8

Carefully position the side rail on top of the tub's top rail.

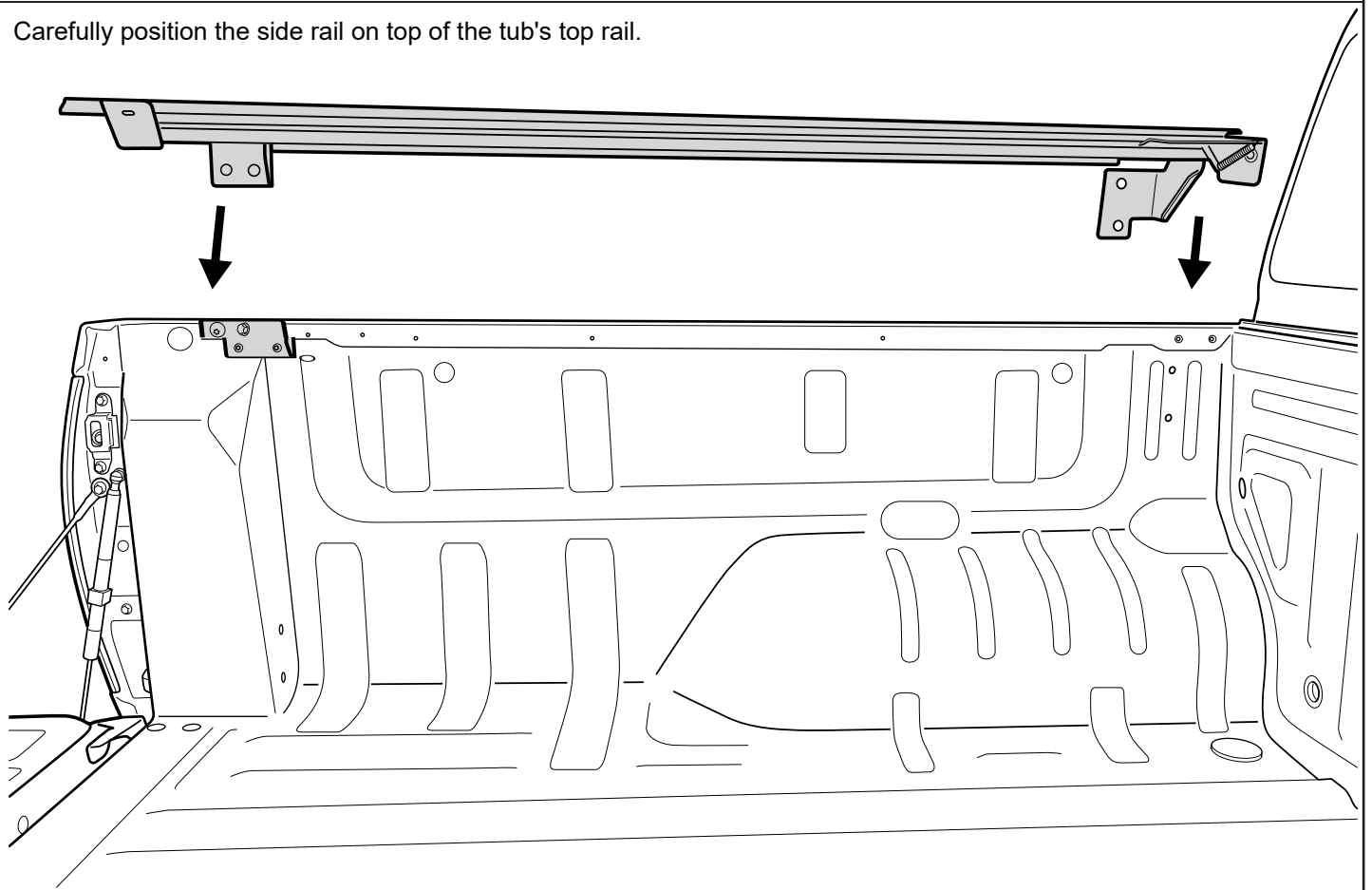

9

- a. Using the supplied M6 socket head bolt assembly, loosely fasten the bracket into place.
- b. Align retained tie down bracket with the holes of the front bracket and the thread of the body.
- c. Using retained factory bolt loosely fasten tie down and side rail bracket into place.

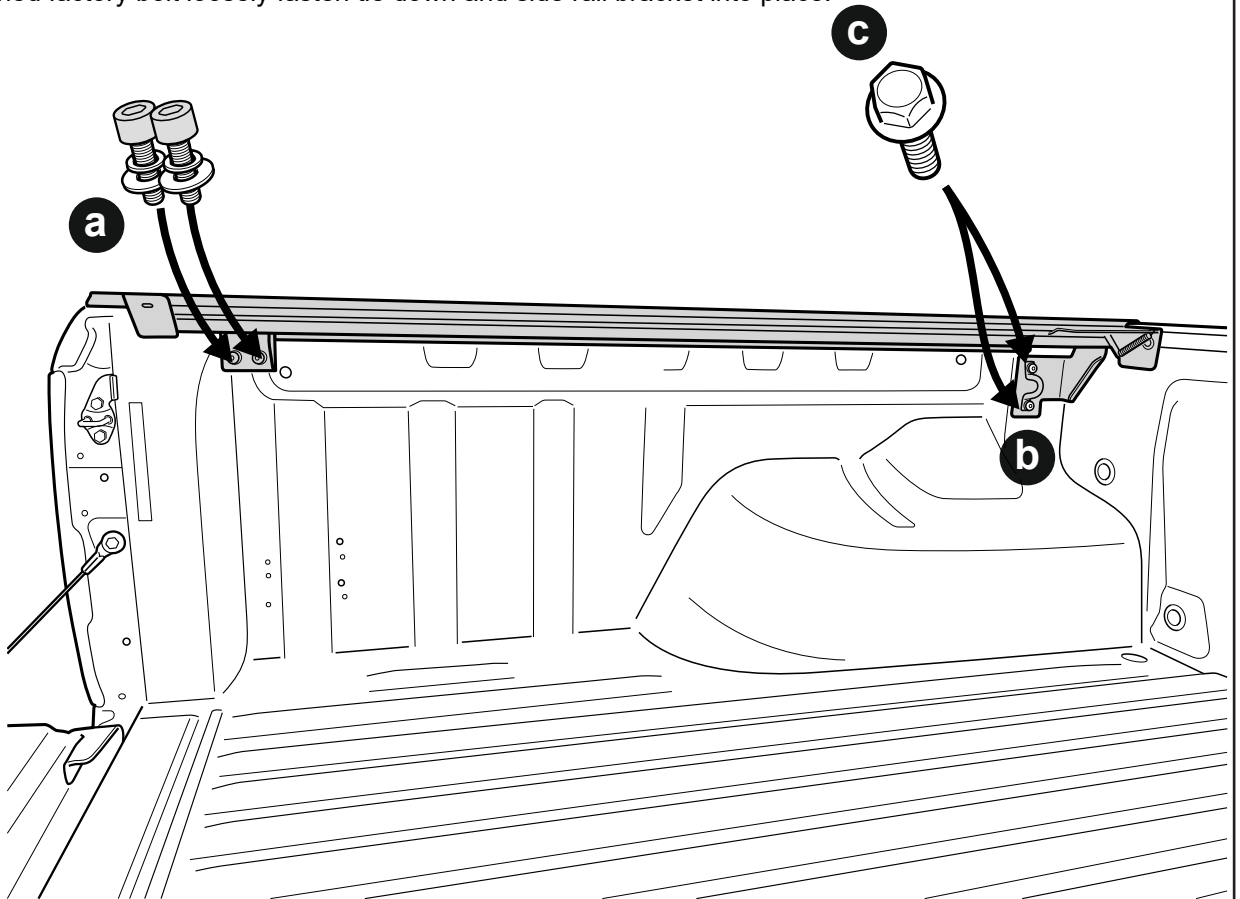

- 10 Carefully push the side rails forward so that the indicated front side rail brackets make firm contact with the headboard.

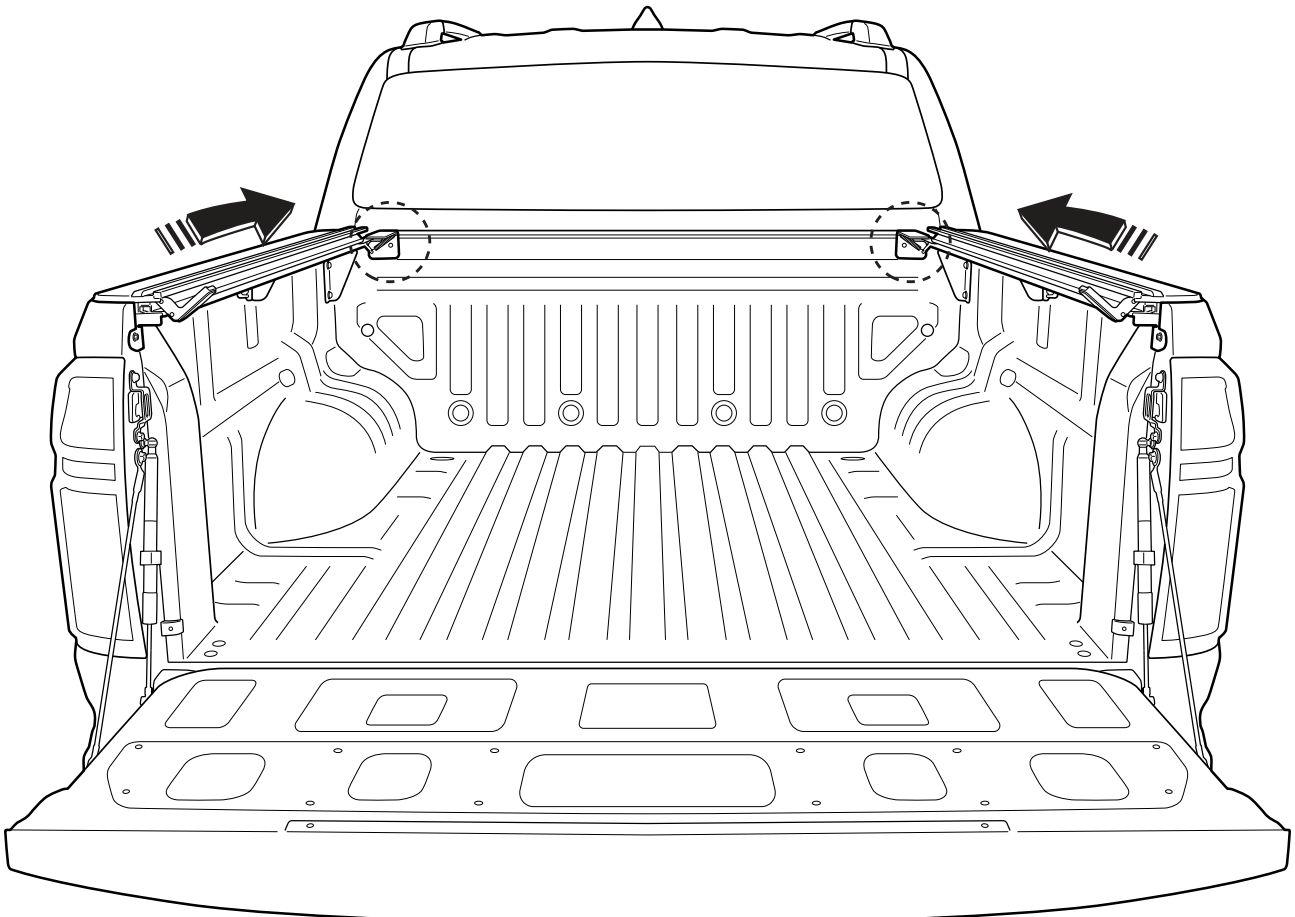

- 11 Carefully pull out any side rubber that has folded under the side rail.

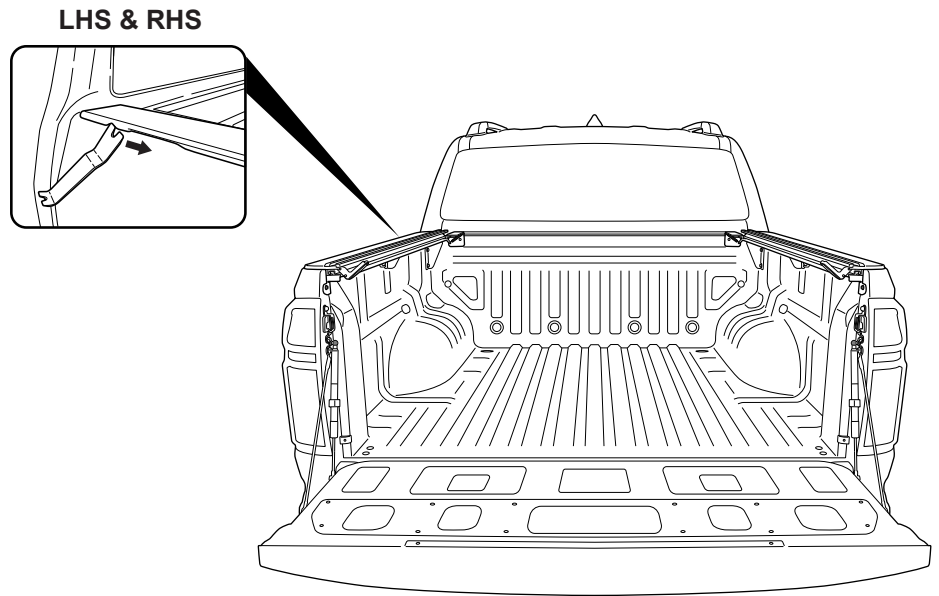

- 12
1. Ensure the side rail alignment is maintained from the previous steps.
 2. Apply slight downward pressure on the side rails and fasten the bolts to a torque of 10 Nm.
 3. Lift or push down on the side rail while testing the tailgate to ensure the side seal of the side rail seal is tucked in by 1-2mm to the top surface of the tailgate. Once properly aligned, fasten the bolts to a torque of 6 Nm.

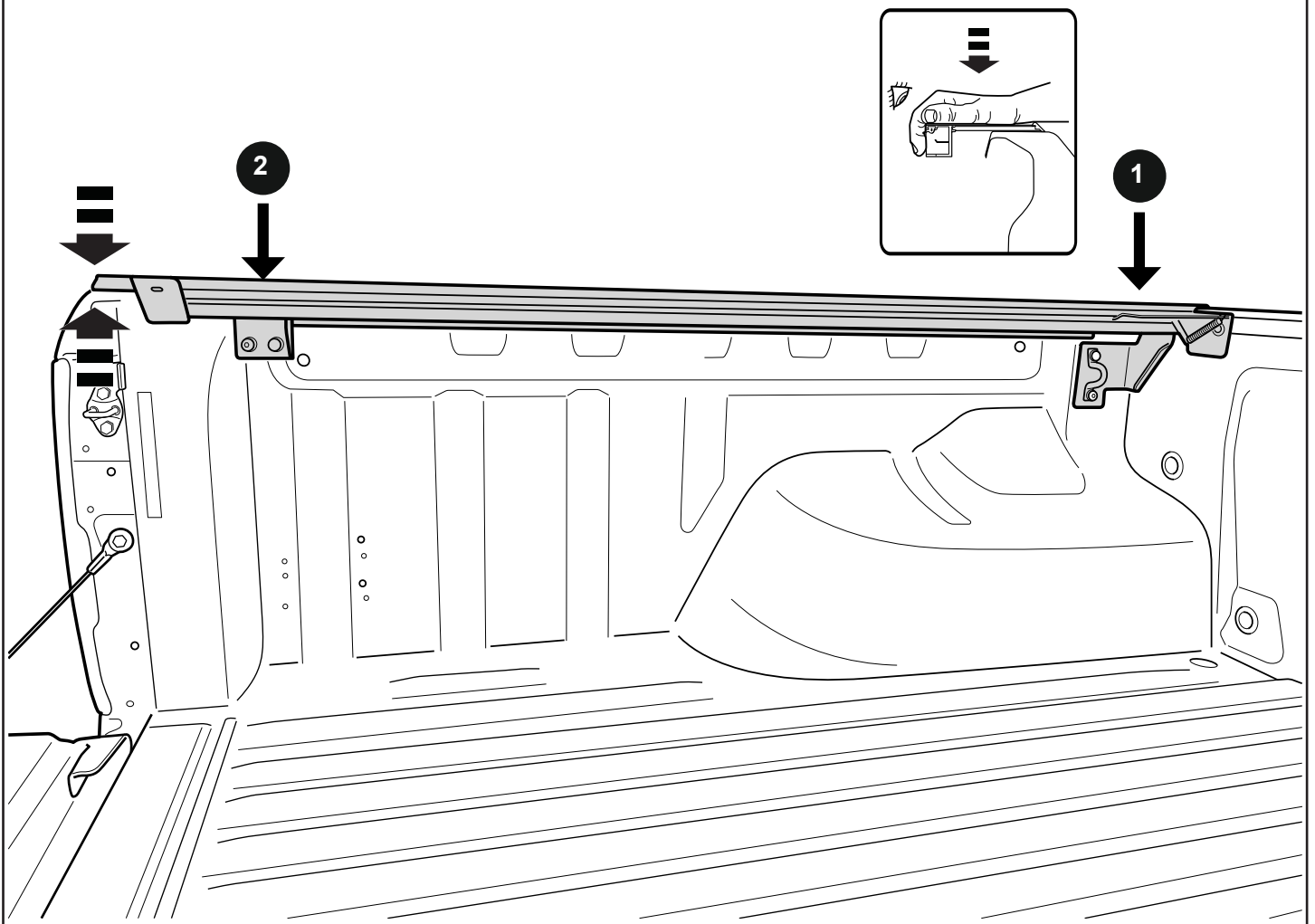

- 13 For accurate alignment of the Roll Mate side rails, refer to the provided measurements. Measure from the outside of the accessory track on one side rail to the outside of the track on the opposite side. Adjust the side rails inward or outward until the desired measurement is achieved, ensuring they remain parallel. (Tolerance: $\pm 1-3$ mm).

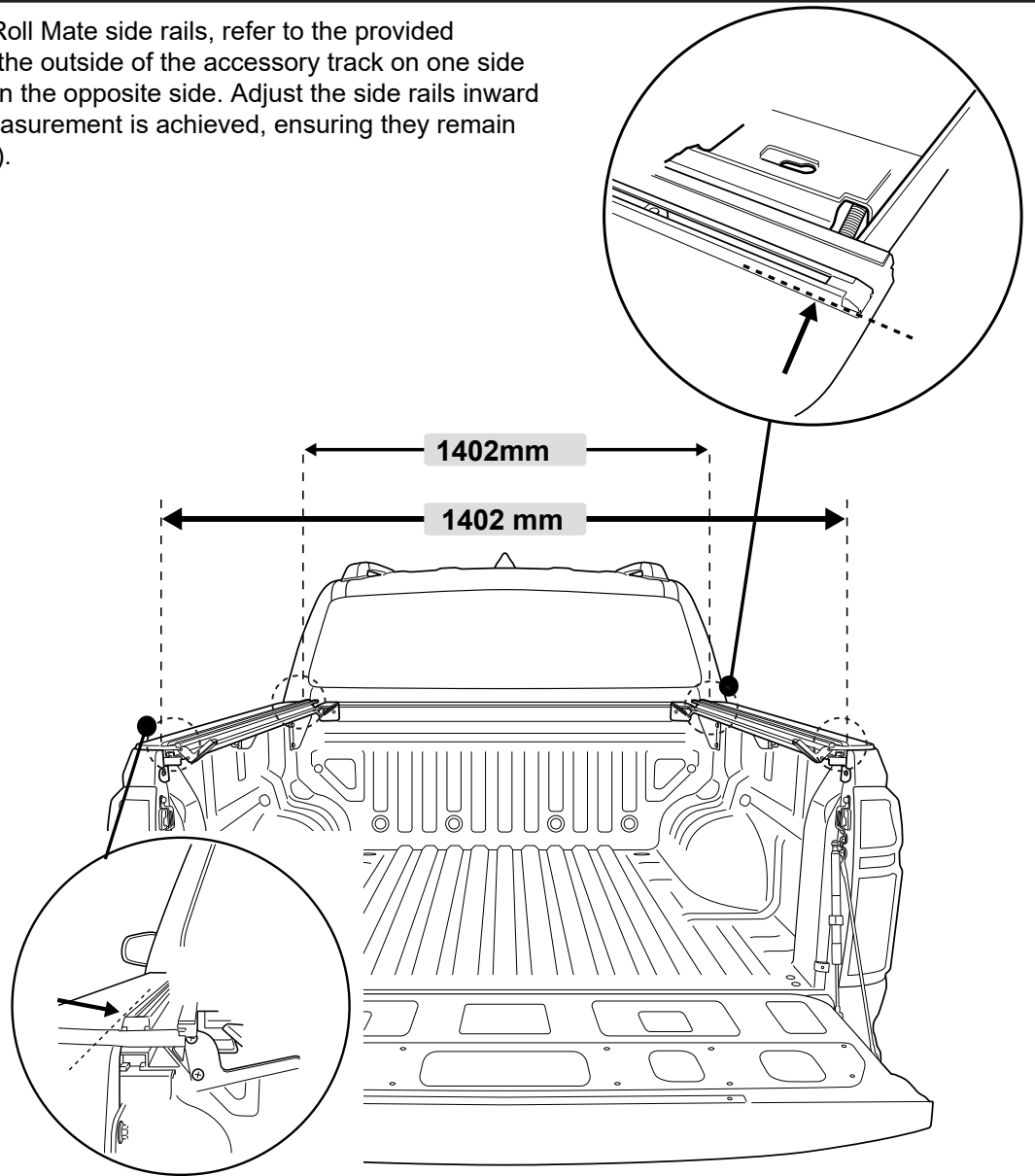

- 14 Fasten indicated bolts to 4Nm torque.

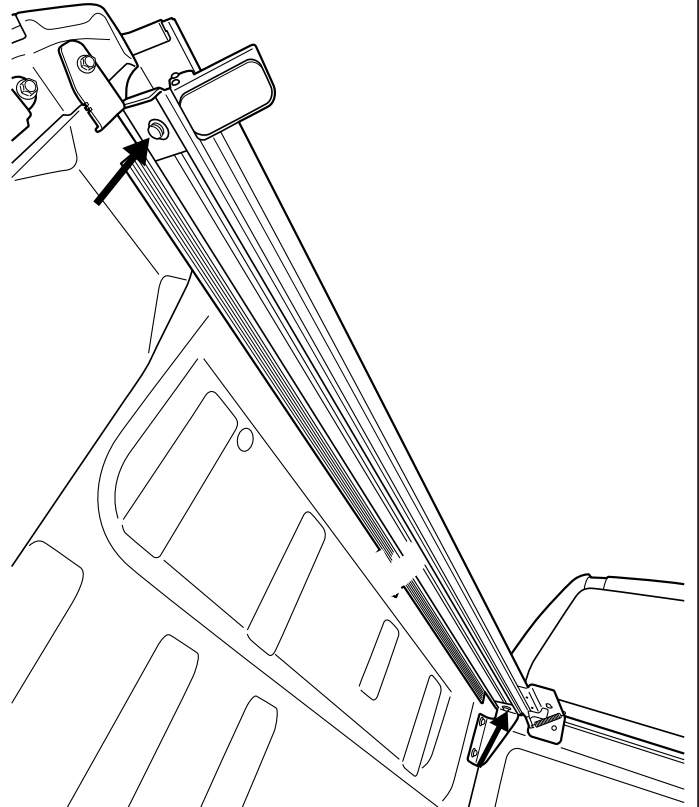

- 15
1. Lift or push down the indicated bracket as needed to ensure the side rails sit level.
 2. Fasten into position using the provided self-drilling screw.

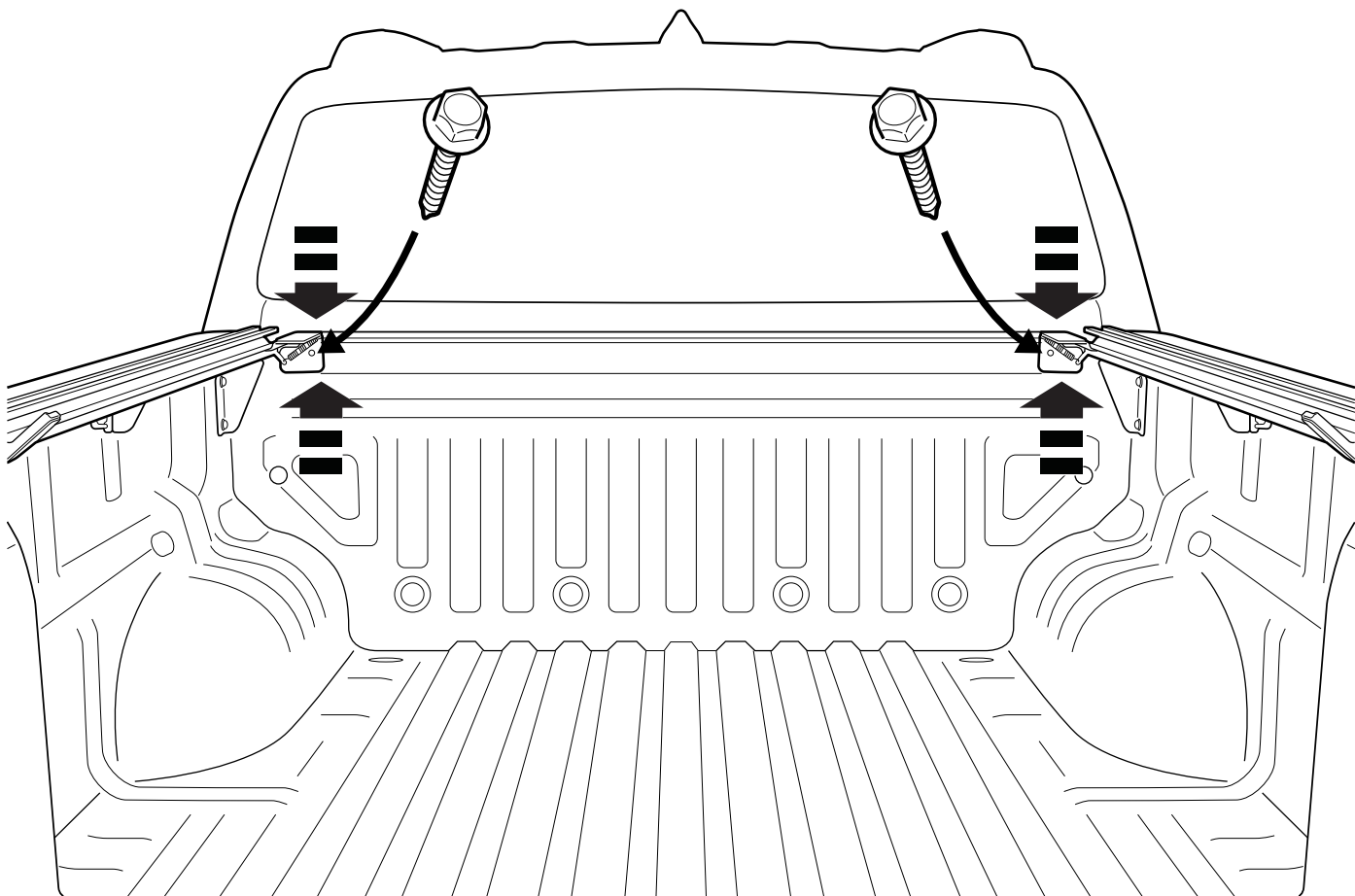

- 16
- Using the supplied connecting keys, insert one key into each side of the indicated channel of the top cover.

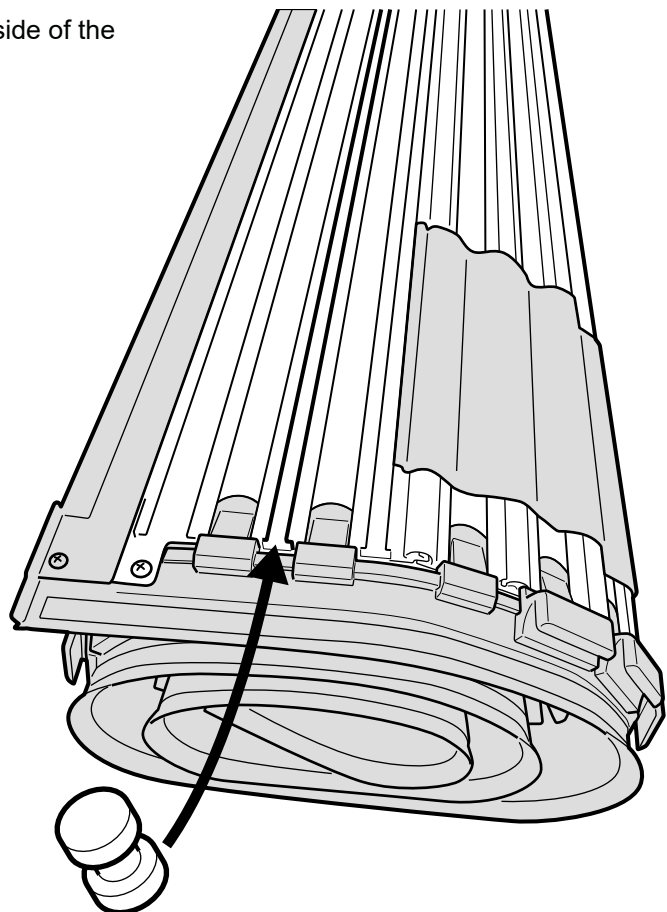

17

- a. Assemble by feeding the T-knob through M8 spring washer and M8 3mm thick flat washer and fastening it to the threads of the Long T-Nut by turning it 4 threads.
- b. Now, in the specified orientation, feed the T-knob assembly into the indicated channel.

Completed view.

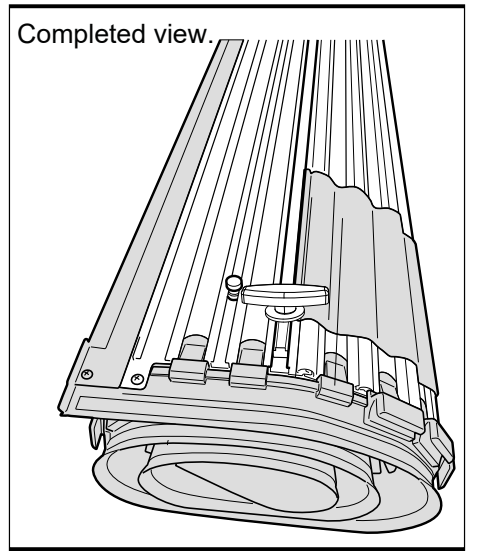
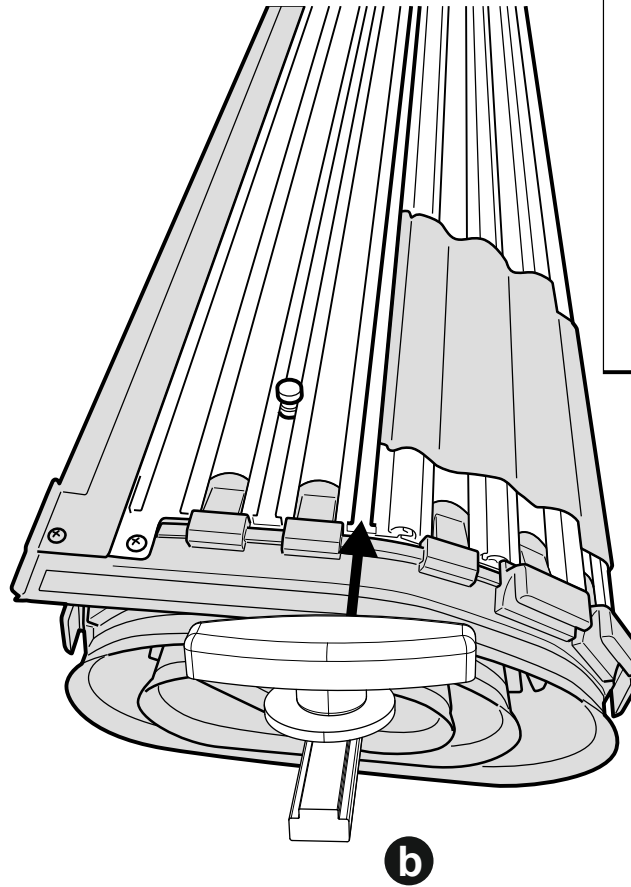
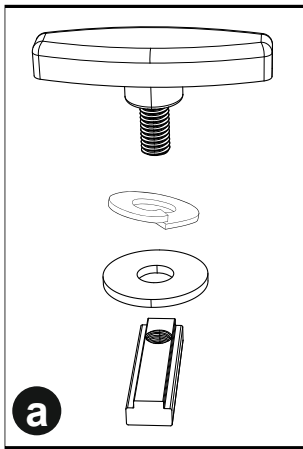

18

With care and with assistance, place the rolled-up top cover onto the front tub.

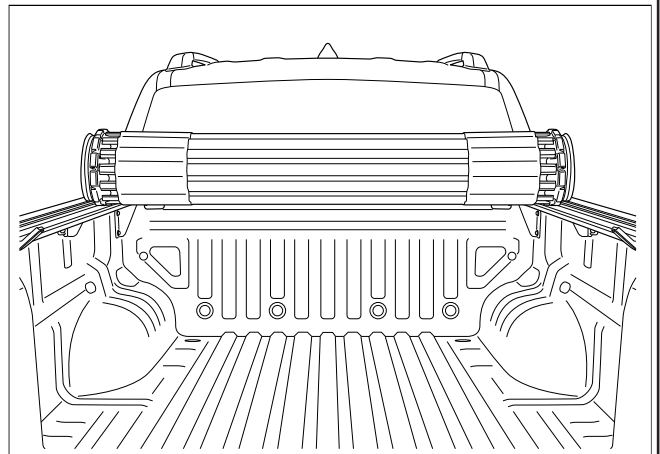
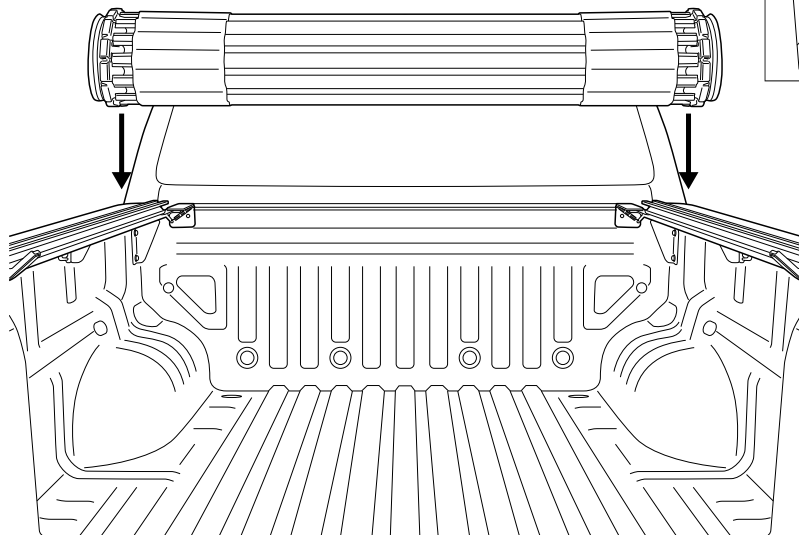
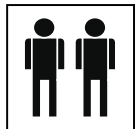

19

1. Wear the disposable glove provided in the primer kit.
2. Apply primer to the indicated inside face of the curtain side rubber. Start from the front and apply about 200 mm towards the back.

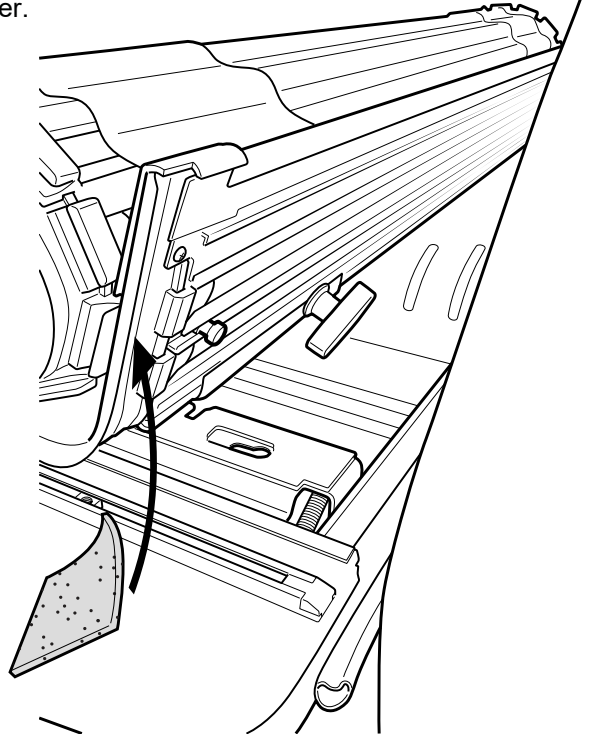
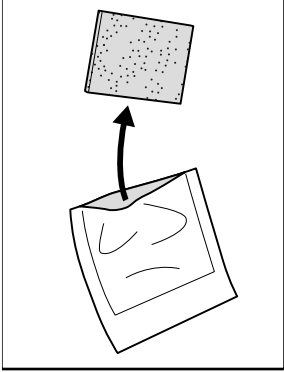

20

- a. Align and push the connecting key through the side rail key slot.
- b. Pull the top cover back toward the tailgate so that the connecting key locks into place in the key slot.

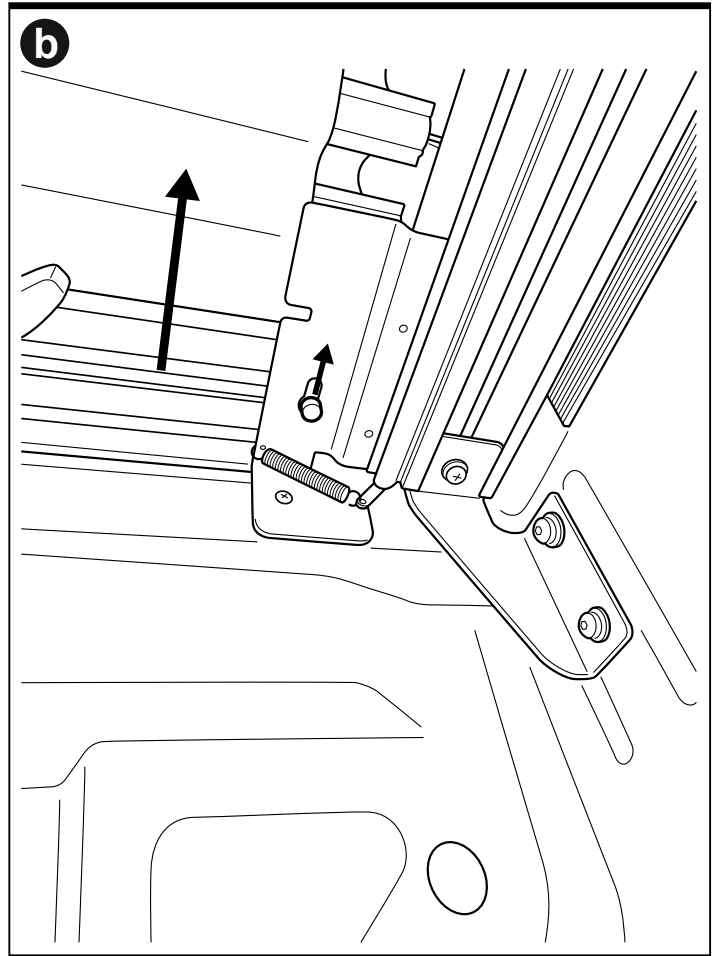
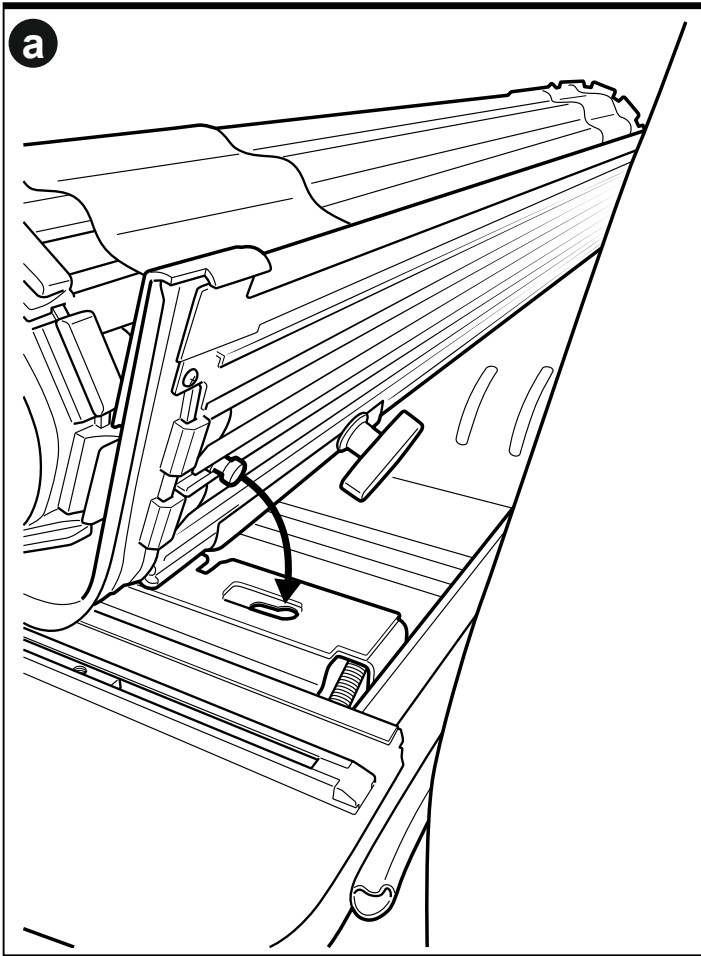
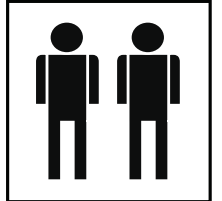

- 21 Slide the T-knob into the indicated bracket slot. (Note: The flat washer should remain between the T-knob and the bracket.) Leave the T-knob bolt loose at this stage.

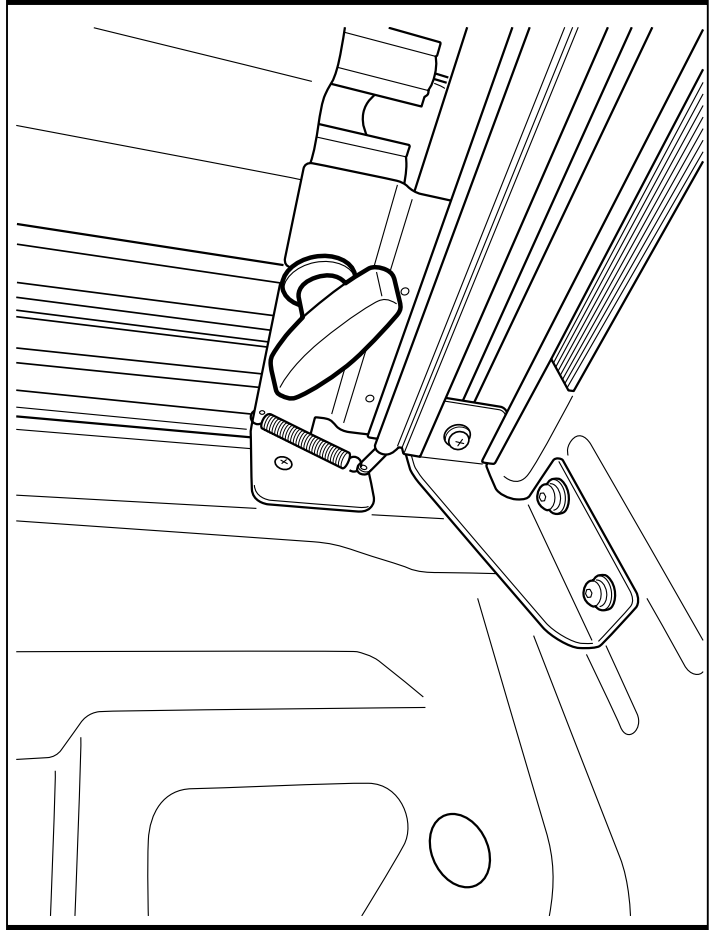
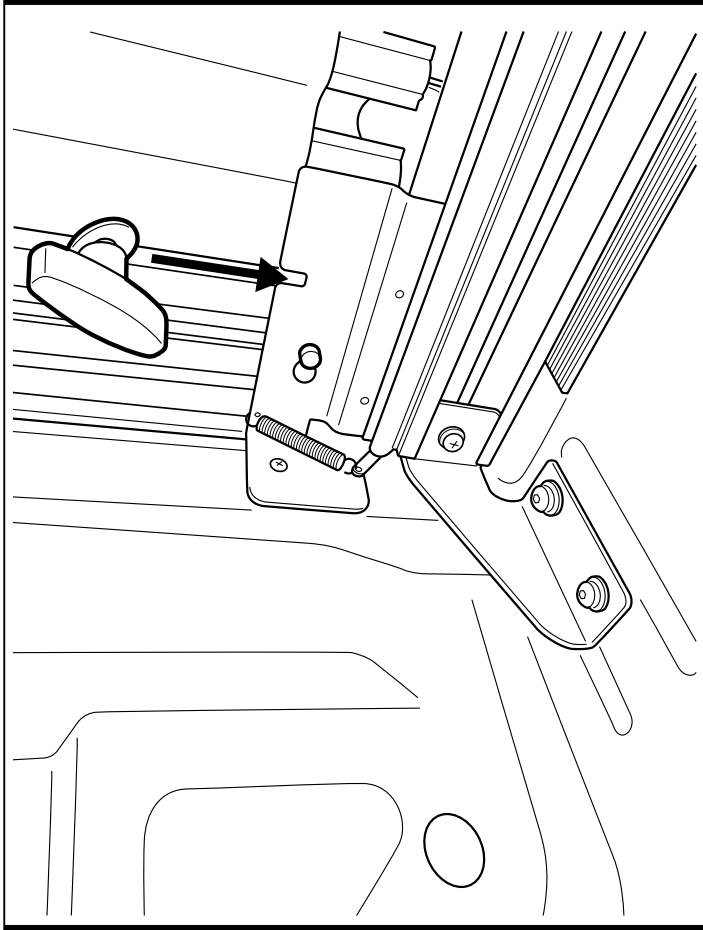

- 22
1. Roll the cover towards the tailgate.
 2. Carefully check its alignment, ensuring the end cap of the top cover maintains a small gap (1–2 mm) from the side rail edge, as indicated.

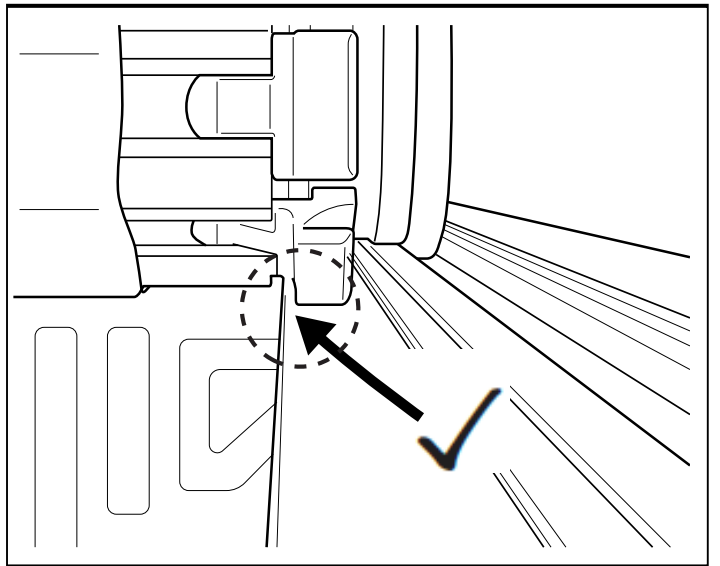
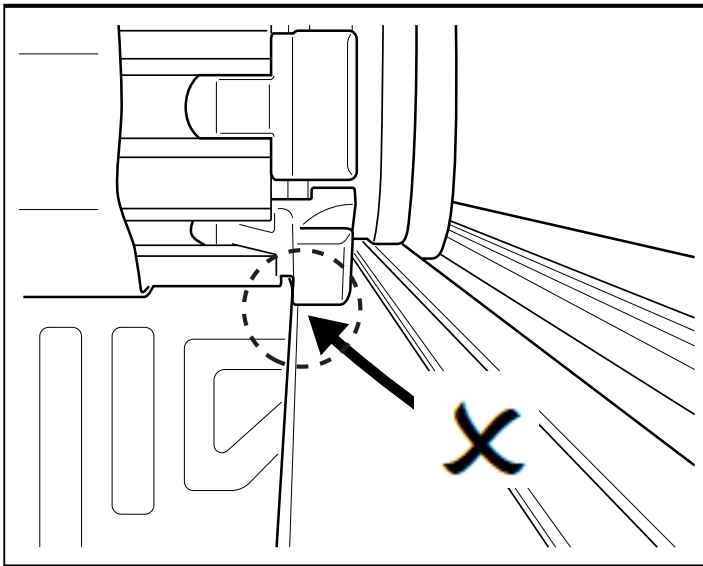
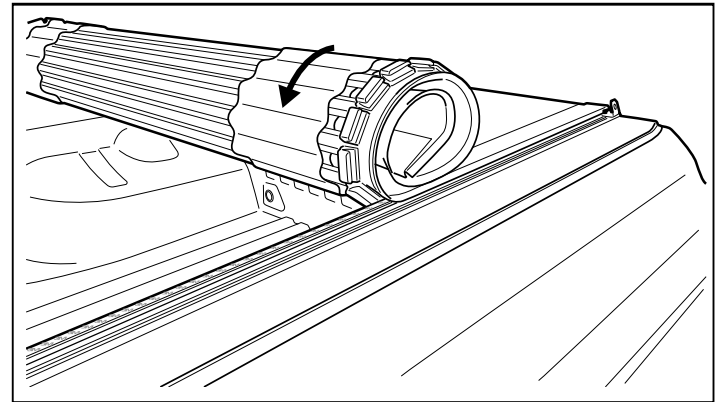

23

1. Pull the cover all the way back towards the tailgate.
2. Carefully inspect along both side rails, ensuring the gap between the cover and the inside edge of the track on each rail is evenly spaced along the entire length, as indicated.
3. If the gap is uneven, gently shift the cover left or right until both sides are parallel and maintain equal clearance throughout their entire length.

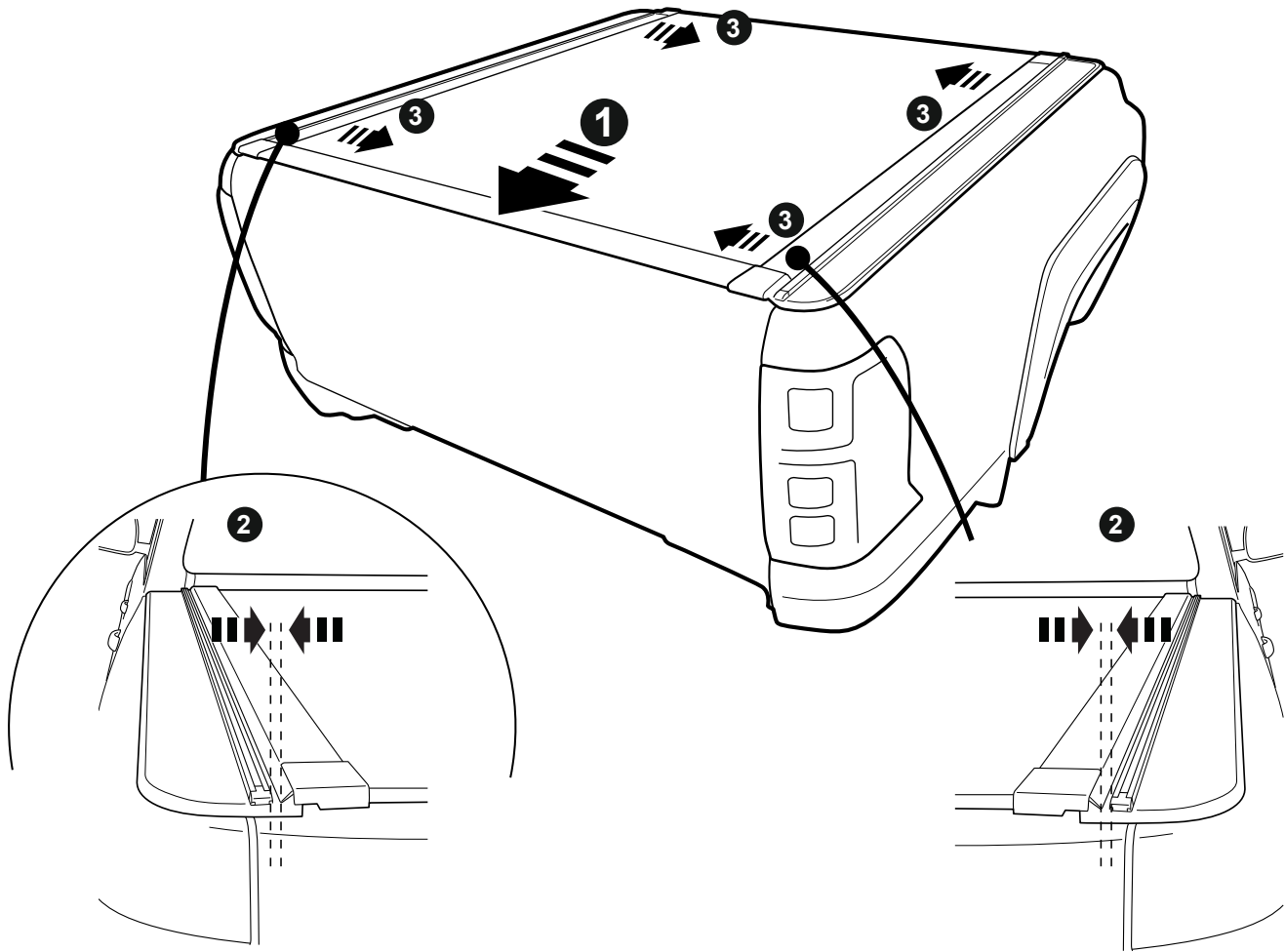

24

- Carefully crawl into the tub, ensuring the alignment of the cover is not disturbed, and securely fasten by turning the indicated T-knob clockwise until firmly tightened.

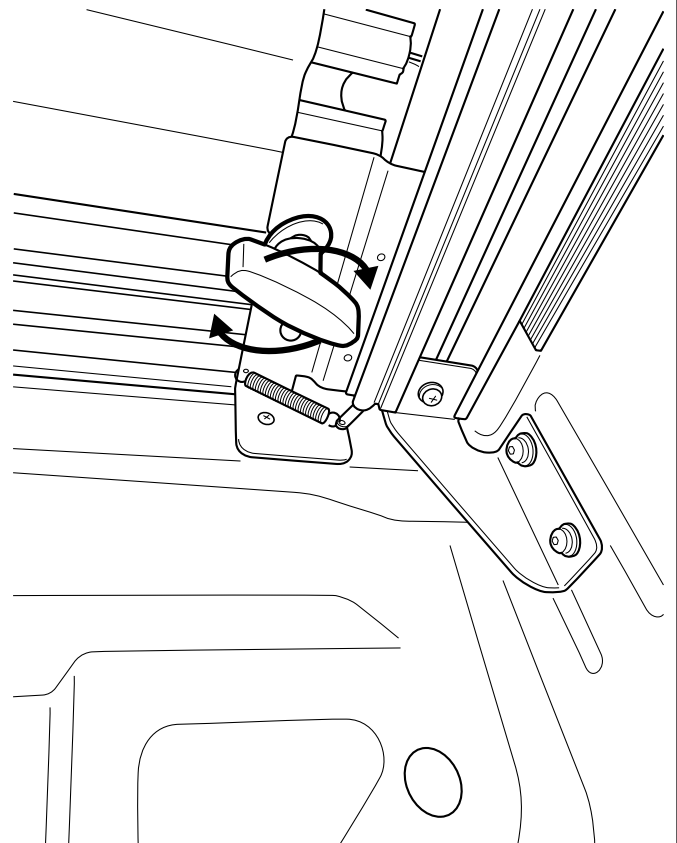

1. Carefully bring the top cover into the locked position. As indicated below, the locking mechanism housing should be clear of the side rail channel by 2 mm, neither more nor less.
2. If adjustment is needed, loosen the indicated screws of the locking mechanism housing and adjust it in or out as required to achieve a 2 mm clearance. Then, fasten the screws back into place.

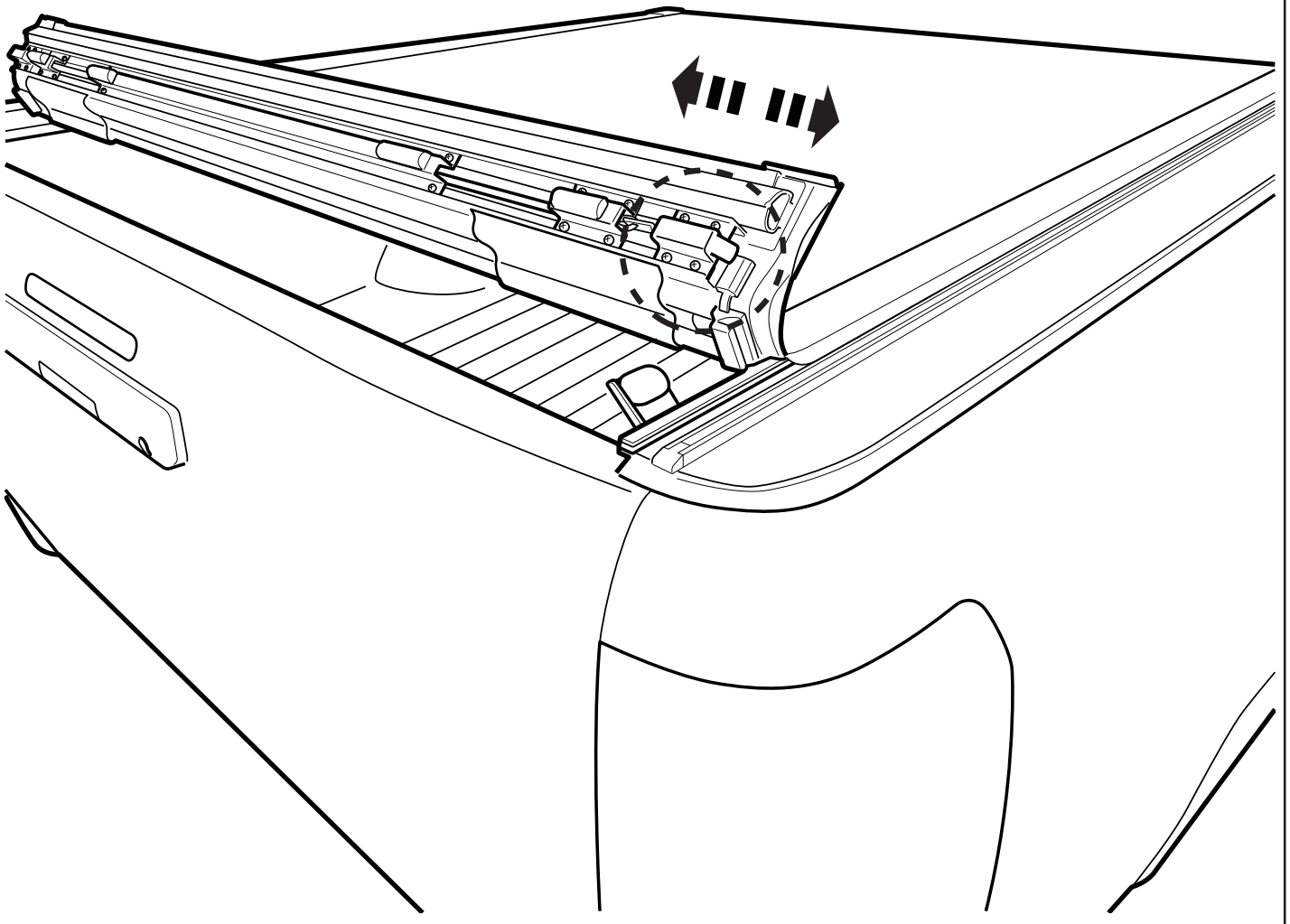
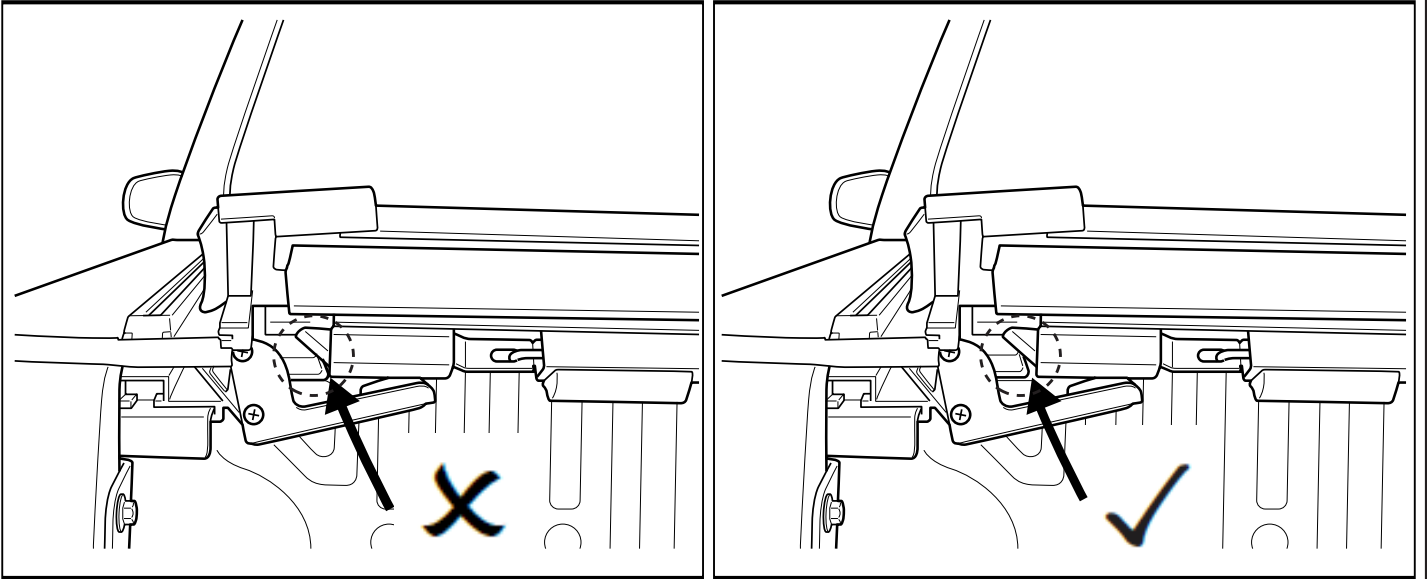

26

1. Wear the disposable glove provided in the primer kit.
2. Apply primer to the indicated inside face of the curtain side rubber. Apply it to from the area that was already primed in earlier steps, extending all the way to the end of the trim.

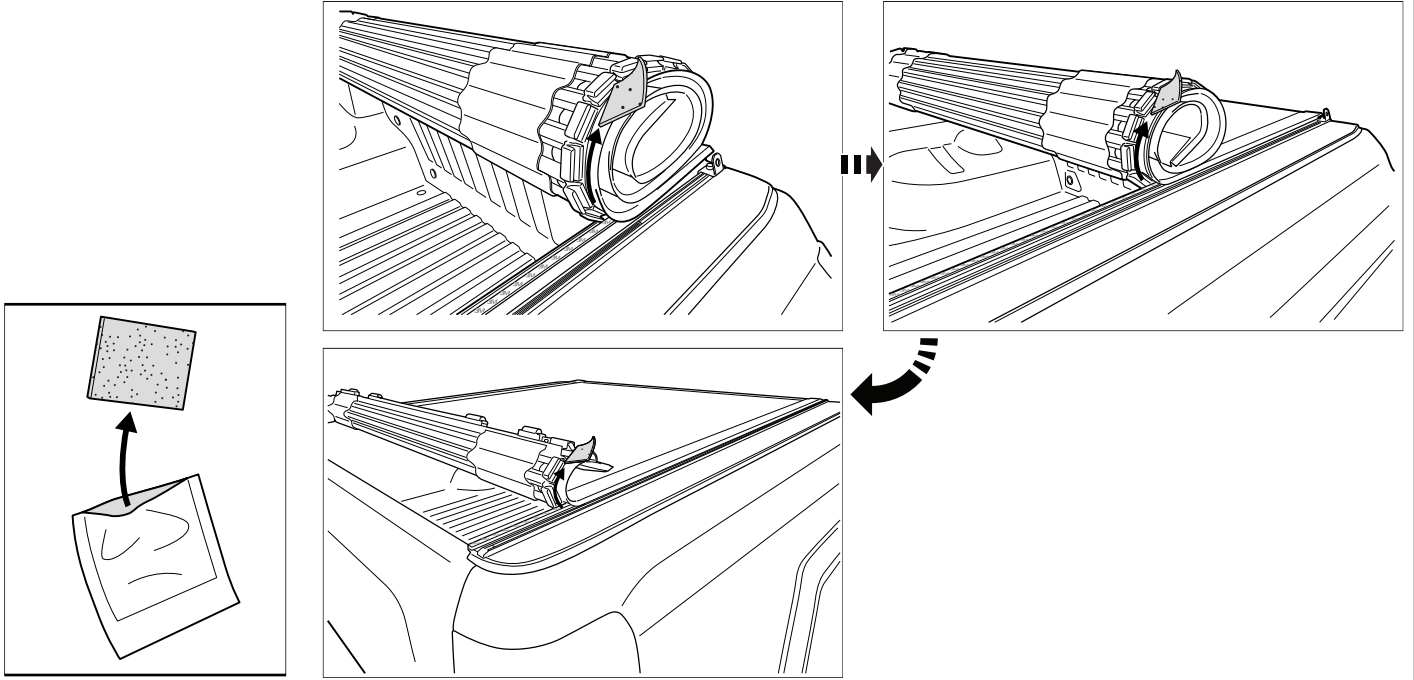

27

- Gradually remove the backing tape from the 3M magnet strip. Apply firm pressure along the top of the curtain side rubber to ensure the magnet strip bonds securely.

Note: Do not roll up the curtain for at least 20 minutes to allow the adhesive to fully bond with the rubber.

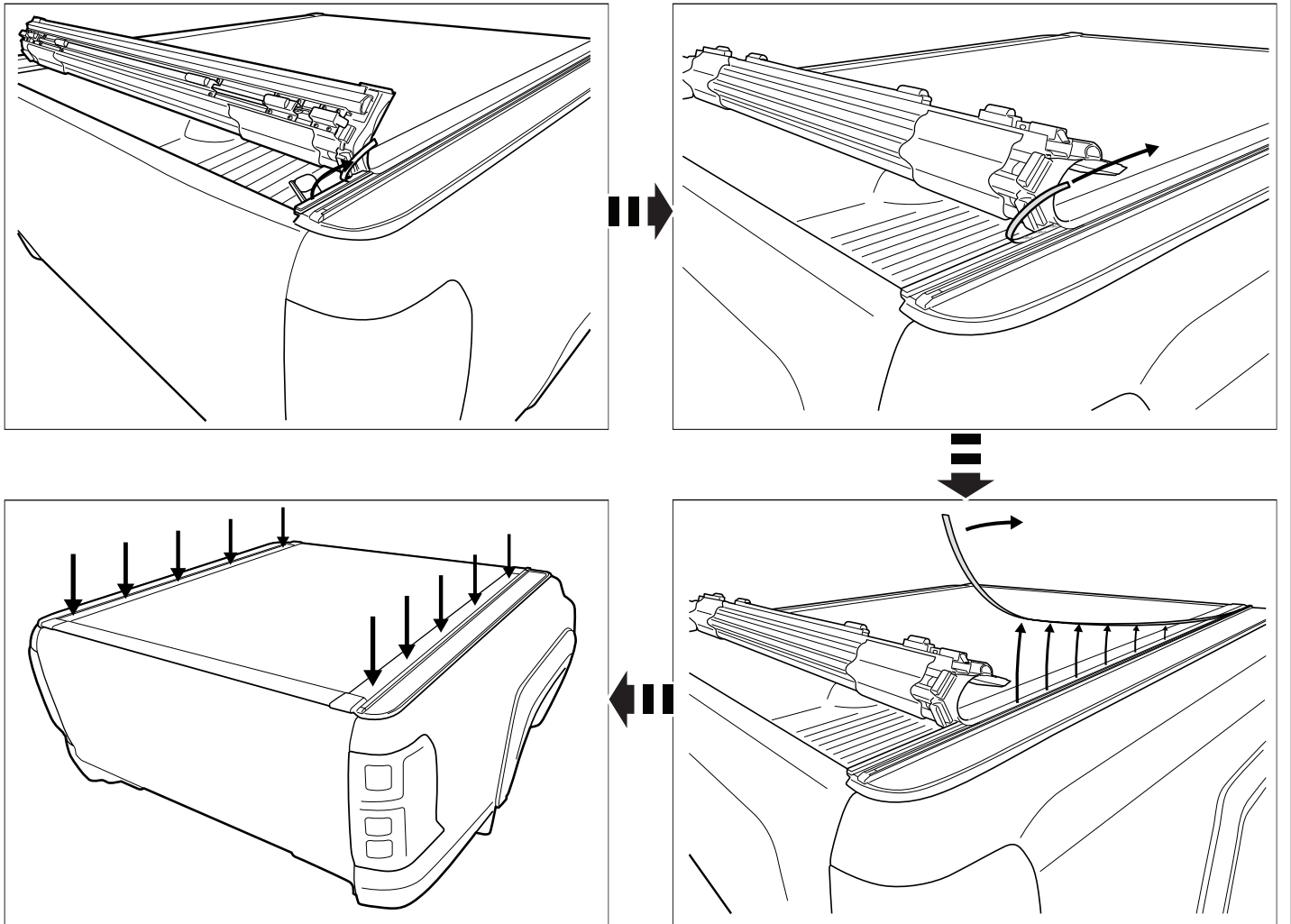

- 28 In the indicated area and orientation, assemble the hook bracket to the side rail's pre-loaded M6 channel nut in the accessory channel using the supplied M6 assembled bolts. Tighten the bolts to a torque of 6 Nm.

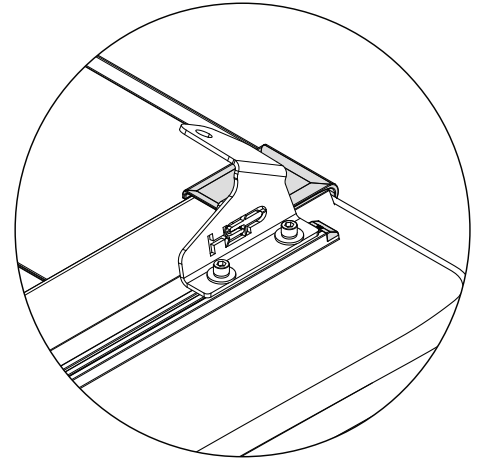
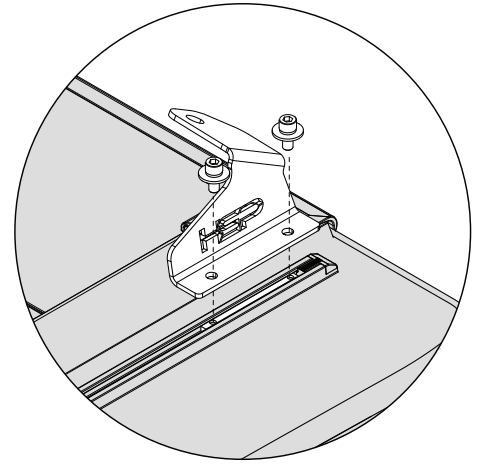
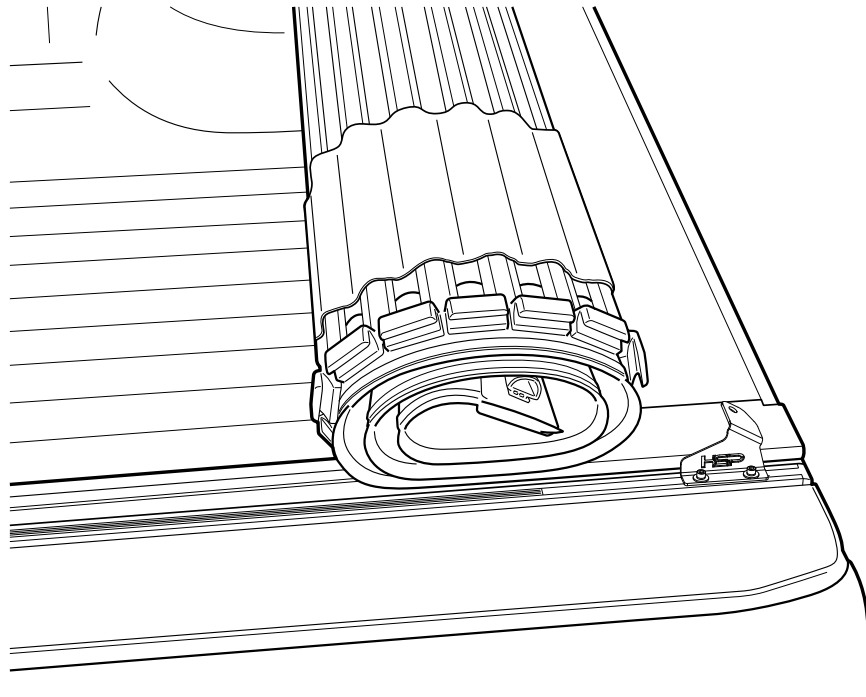

- 29 In the indicated orientation, insert the hook through the hole in the hook bracket.

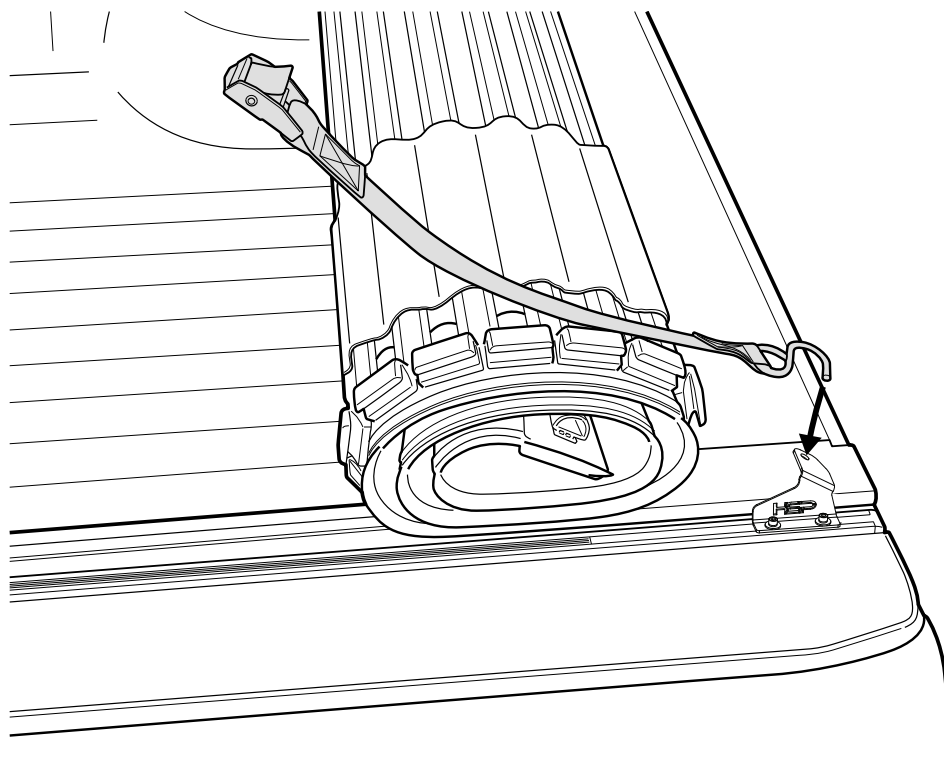
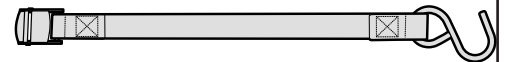

- Loosely fasten the indicated end of the strap to the spare channel nut underneath the side rail using the supplied M6 assembled bolt.
- In the indicated orientation feed the strap through the cam buckle.
- Slightly pull strap away from the buckle.
- Pull the strap towards the rear of the Ute to remove the slack, leaving it loose.
- While the cover is rolled up, move the strap underneath the side rail so that it is 200 mm away from the cover. Then, fasten the screw to 6 Nm of torque.
- Keeping the strap inside the curtain end caps, pull the strap away from the buckle to compress and tighten the curtain into place.
- Strap location completed.

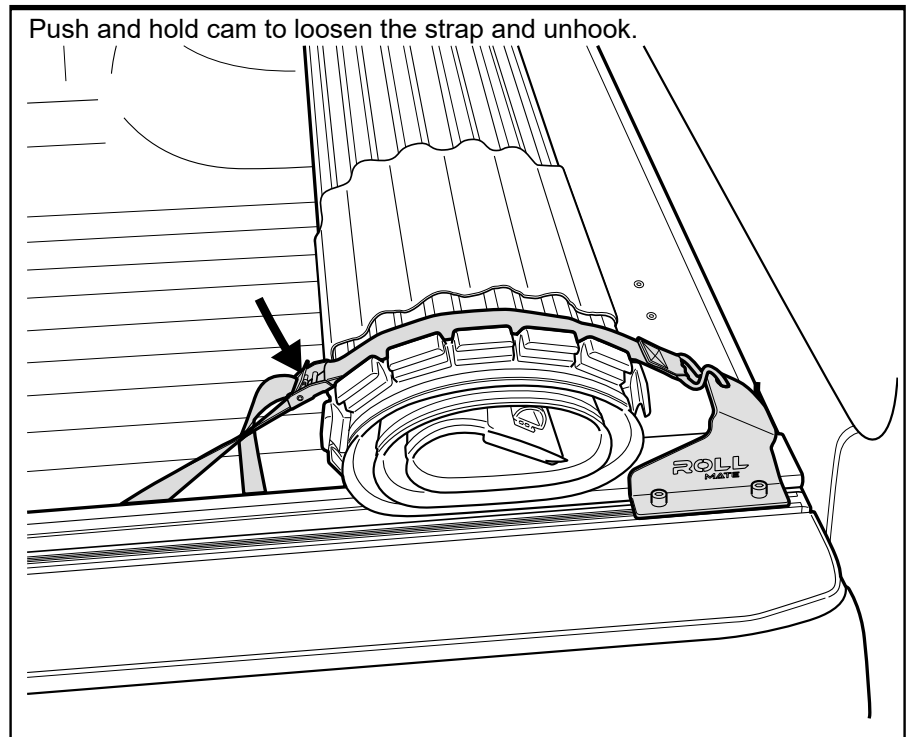
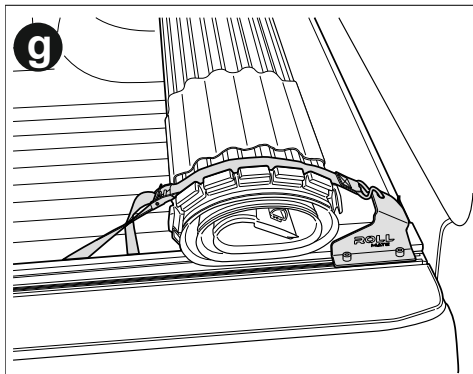
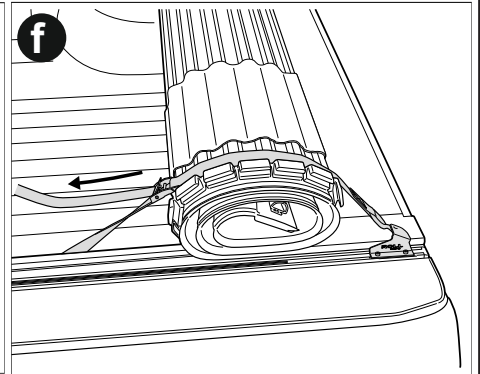
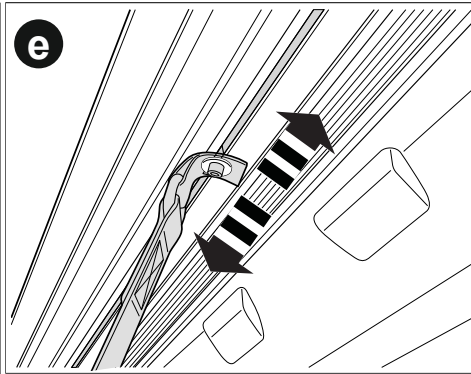
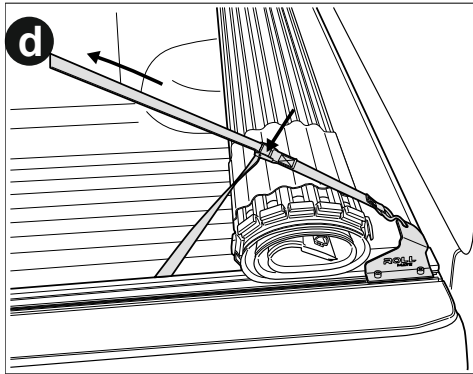
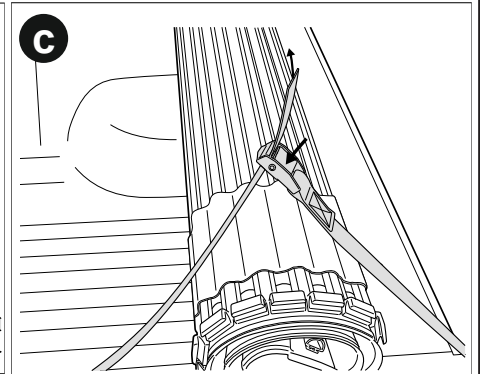
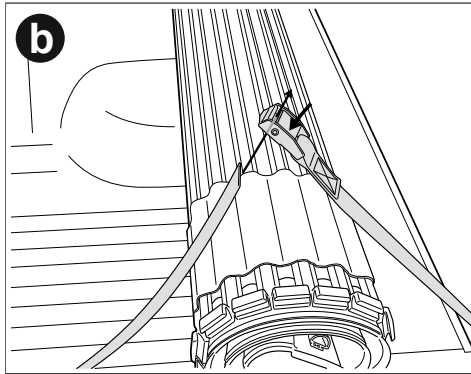
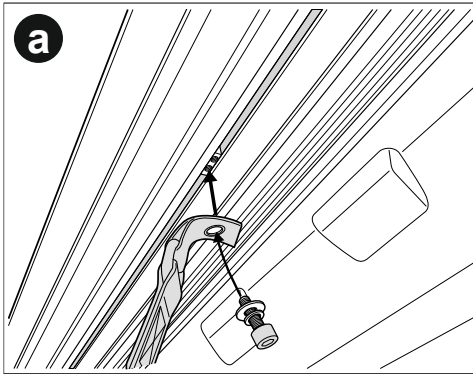
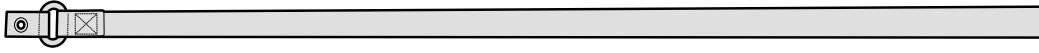

1. Clean the area with a non-oil-based cleaner, such as an alcohol wipe.
2. Apply clear protective tape to the left and right top corners of the tailgate as indicated.

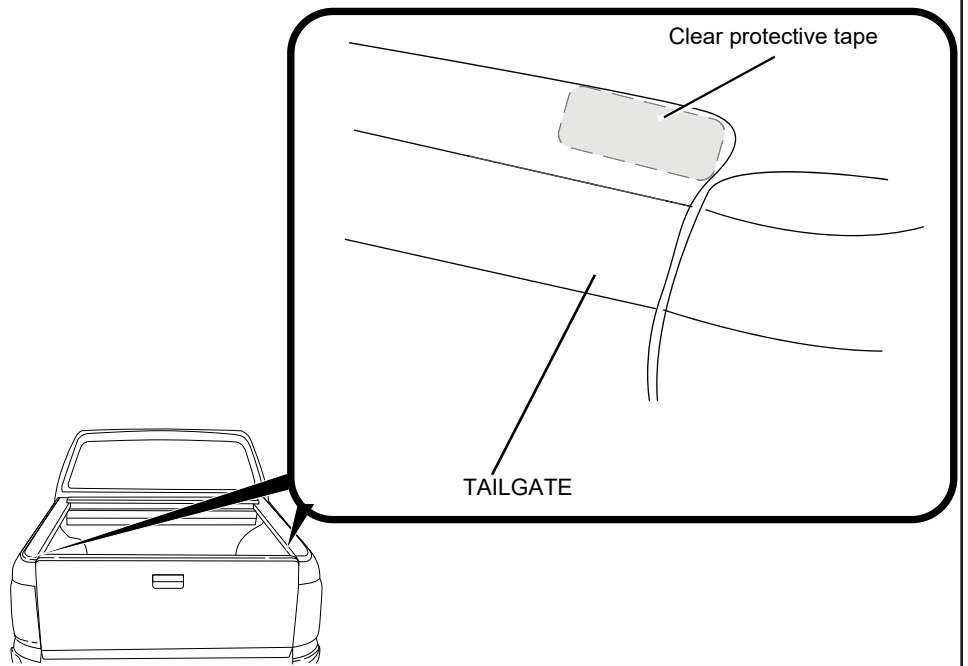

HOW TO OPERATE YOUR ROLL MATE

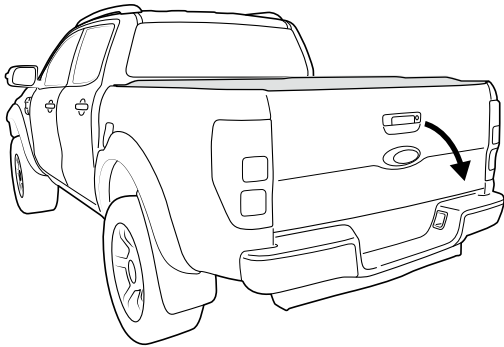

Open the tailgate

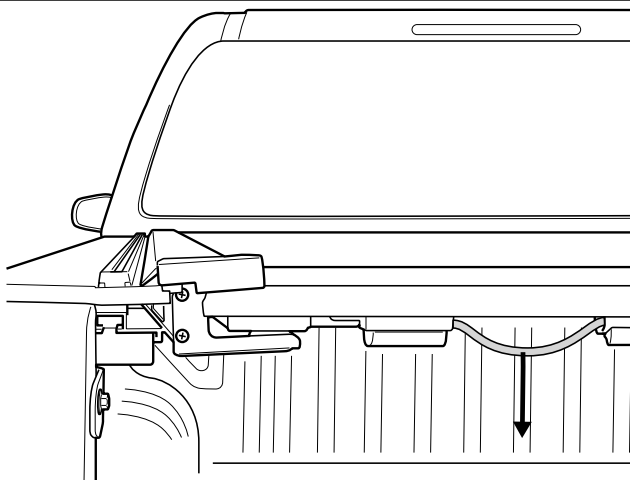
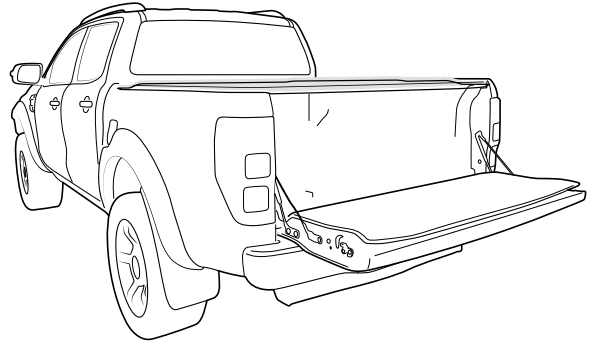

Gently pull on the indicated release cable located on either side of the cover to release the latch.

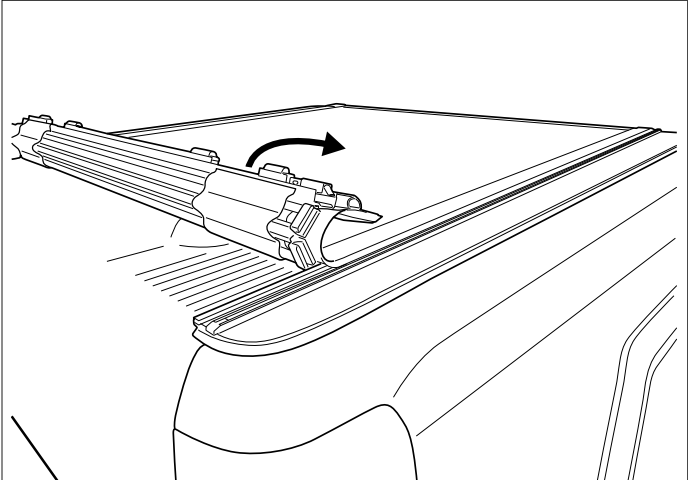

Now, rotate the cover forward in a rolling motion.

When driving with the cover open, the cover must be rolled toward the cabin and secured with both straps.

- In the indicated orientation, insert the hook through the hole in the hook bracket.
- As needed, carefully push and hold the cam while pulling the strap toward the rear of the Ute until the cover compresses and has no back-and-forth movement.
- secured view.

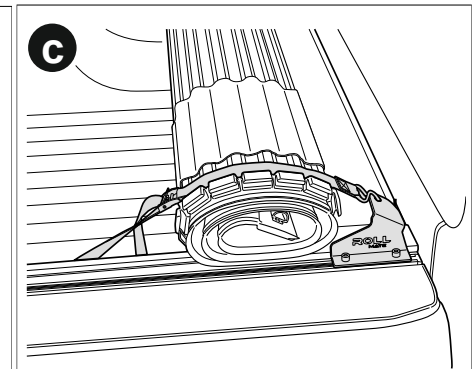
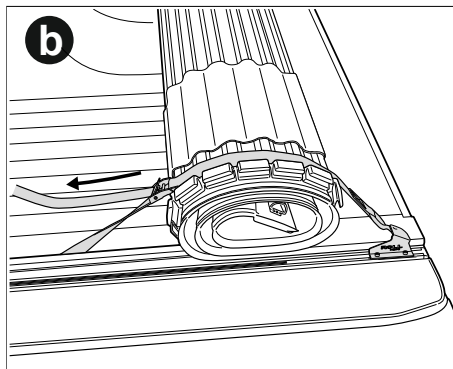
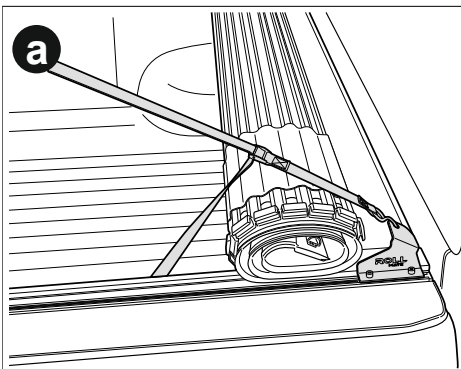

Push and hold cam to loosen the strap and unhook.

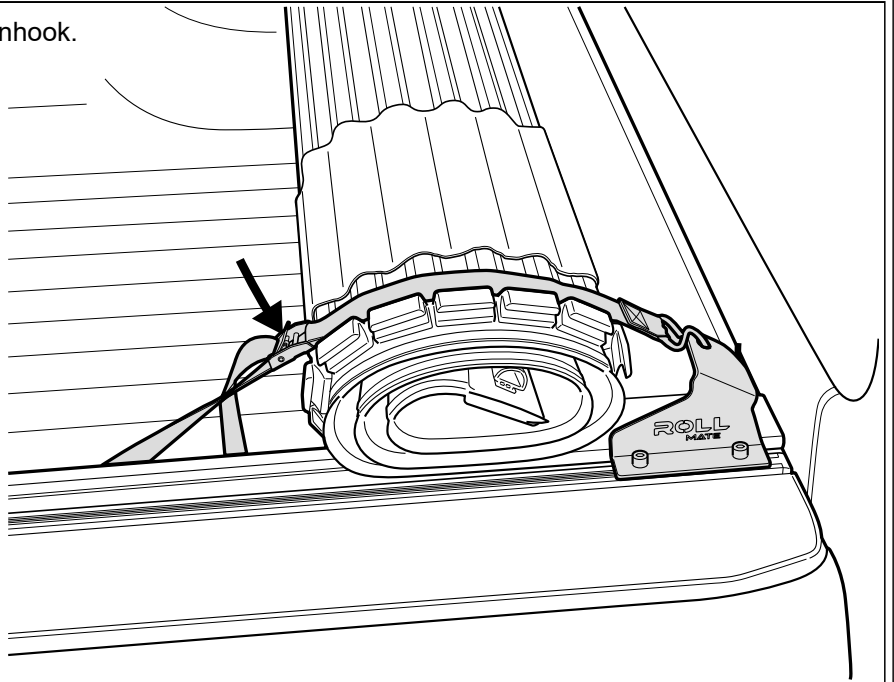

a. Rotate the cover open towards the tailgate in a rolling motion.

b. Push down on each corner of the cover. You will hear a click, indicating that the cover has latched into place.

a

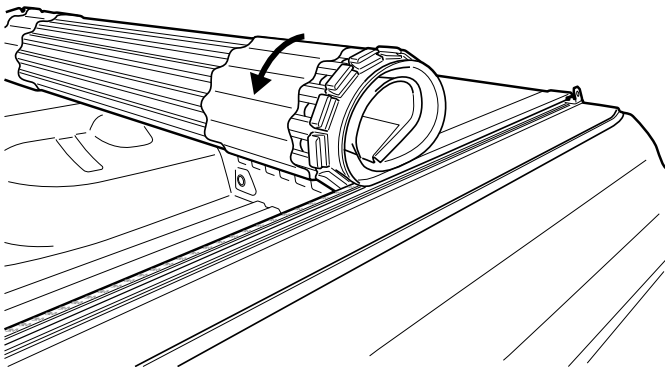

b

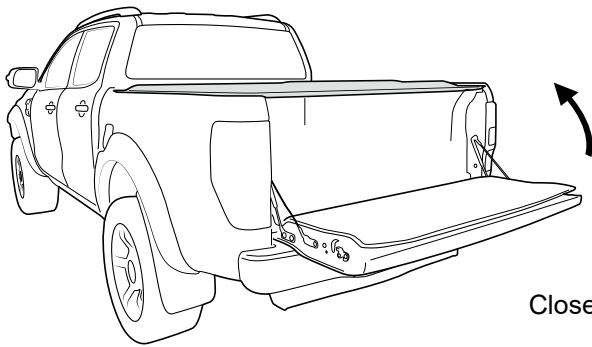
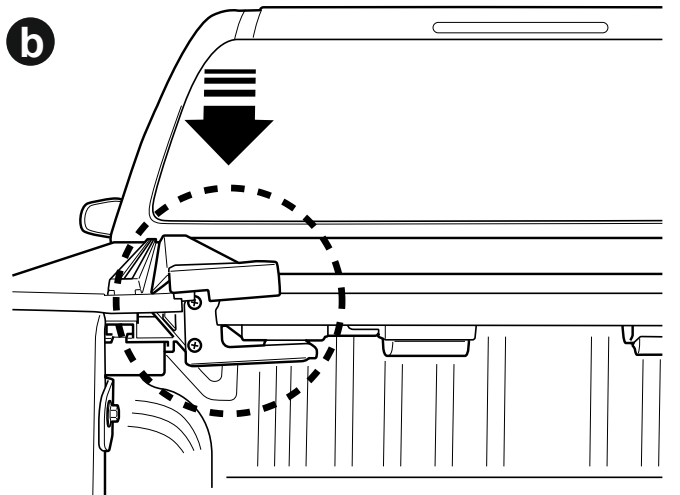

Close the tailgate

